

DERWENT WORLD PATENTS INDEX®
(DWPISM)

Tools of the Trade on STN

© 2006 The Thomson Corporation. All rights reserved

Edition 3
ISBN: 1 903836 95 9

© 2006 The Thomson Corporation
Published by Thomson Scientific
14 Great Queen Street, London WC2B 5DF,
United Kingdom

Visit the Thomson Scientific web site at www.scientific.thomson.com

Second edition published January 2000
Second edition (revised) published May 2000
Third edition published August 2006

ISBN: 0 901157 18 X Second edition
ISBN: 0 901157 78 3 Second edition (revised)
ISBN: 1 903836 95 9 (Third edition)

All rights reserved. No part of this publication may be reproduced, stored in a retrieval system or transmitted in any form or by any means – electronic, mechanical, recording, photocopying or otherwise – without express written permission from the copyright owner.

Contents

Introduction	1
Who is Thomson Scientific?	1
What is <i>DWPI</i> ?	1
Why do I want to use <i>DWPI</i> ?	2
Sounds interesting, how do I get started?	2
How to Read a <i>DWPI</i> Record	3
STN Basic Searching Techniques	12
Basic STN Commands	12
Truncation	12
Combining Search Terms	13
Proximity Operators	13
Displaying <i>DWPI</i> Information	14
Patent/Publication Number Searching	16
Japanese Publication Number Searching	18
Application/Priority Number Searching	21
Complete Patent Family Searching	23
Inventor Searching	26
Assignee/Company/Agent Searching	28
Using Date Ranging, <i>DWPI</i> Country Information and <i>DWPI</i> Update/Year(s)	31
Searching for Dates	31
Searching for Country Information	32
Searching <i>DWPI</i> Update/Year	32
Using <i>DWPI</i> Update Codes and Accession Numbers	33
<i>DWPI</i> Update Codes	33
Searching <i>DWPI</i> Accession Number(s)	34
Subject/Keyword Searching	35
<i>DWPI</i> Basic Index	36
Abstract Styles	37
Abbreviations	38
British/American Spellings and Terminology	38
<i>DWPI</i> Extended Basic Index	38
Using the <i>DWPI</i> Classification System	40
Using the International Patent Classification System	44

Using <i>DWPI</i> Manual Codes	49
Competitive Intelligence: Early Warning	53
Creating a Current Awareness Profile (SDI)	56
<i>DWPI</i> Country Coverage and Kind Codes	58
<i>DWPI</i> Country Coverage Date of Inclusion	64
Thomson Scientific Standard Abbreviations	66
Glossary of Patent Terms	68
Further Information	70
Customer Technical Support	70
Contact Details	70
Thomson Scientific Website	71
Customer Support Center	71
Customer Training	71
Patent Copy Service	72
User Guides	72
Online Sources	73
Electronic Resources	73
Other Thomson Scientific databases available on STN	74

Introduction

Thank you for your interest in *Derwent World Patents Index (DWPI)* on STN. In order to familiarize you with *DWPI*, here are the answers to some of the most common questions you might have.

Who is Thomson Scientific?

Thomson Scientific is part of the Scientific & Healthcare market segment of The Thomson Corporation. We combine authoritative information with innovative technologies to enhance our customers' ability to achieve world-class research and business results.

The following information brands make up Thomson Scientific:

- BIOSIS
- Current Drugs
- Current Patents
- Delphion
- Dialog
- IDRAC
- Liquent
- MDC
- Micromedex
- Micropatent
- Newport Strategies Inc.
- Techstreet
- Thomson Derwent
- Thomson ISI
- Thomson ResearchSoft

What is *DWPI*?

For over fifty years *DWPI* has been foremost in providing scientific and technical intelligence to business, industry, government, and research institutes throughout the world and is the world's most comprehensive value-added database of international patent information. *DWPI* provides access to information from more than 30 million patents, giving details of over 14 million inventions. Each week data are added from more than 20,000 documents from 41 patent-issuing authorities.

Each record in *DWPI* describes a 'Patent Family', starting with the new invention (Basic Patent) and adding information about the same invention issued in other countries (Equivalent Patents). Our experienced analysts read each document in its native language and then rewrite the titles and abstracts in English to create an enhanced value-added *DWPI* record. Also included in the record is the drawing from the patent that is most representative of its claims and special indexing to help you search for key patent information. Additionally, the original titles, abstracts, claims, and/or bibliographic data may be present to complement the *DWPI* value-added record.

Why do I want to use *DWPI*?

- to determine the extent to which an invention has been protected internationally
- to search for English language equivalents in order to review patent documents published in an unfamiliar language
- to research technological advances within your field
- to find potential gaps in the marketplace
- to review the novelty of your company's invention
- to track technological trends within your field
- to avoid/watch for patent infringement
- to identify competitors and monitor their activities

Sounds interesting, how do I get started?

Log into STN and access the *DWPI* database. If you do not have an STN login ID or need additional assistance, please contact our friendly and knowledgeable Customer Technical Support staff. Turn to page 70 of this guide for contact details of your nearest Support Center.

How to Read a *DWPI* Record

Geographic Coverage:	41 Patent-issuing authorities and 2 literature sources
Historical Coverage:	Pharmaceuticals from 1963 Agriculture and Veterinary Medicine from 1965 Plastics and Polymers from 1966 All Chemistry from 1970 All Technology from 1974
Available Patent Drawings:	Engineering and Electrical documents 1988 to present Chemical documents 1992 to present
STN Host Information:	File WPINDEX (open access) File WPIDS (subscriber only*) File WPIX (subscriber only*)
Database Update Frequency:	Every 3-4 days

*You must have a valid subscription with Thomson Scientific to access the subscriber versions of the *DWPI* database. For more information please contact your local Thomson Scientific Support Center.

DWPI enhanced value-added record	Records until 1999 (for records from 1999 onwards, please see pages 6-11).																																																																									
Accession Number see page 33	ACCESSION NUMBER: 1999-097448 [09] WPINDEX	Displaying DWPI Information see page 14																																																																								
DWPI Title see page 35	ENTRY DATE: 20050520 DOC. NO. NON-CPI: N1999-070925 [09] TITLE: Golf club, especially driver - has titanium head, plastic neck, and graphite shaft																																																																									
Inventor see page 26	DERWENT CLASS: P36 INVENTOR: KUBICA D J; NOBLE R B	DWPI Classification see page 40																																																																								
	PATENT ASSIGNEE: (KARS-N) KARSTEN MFG CORP	Patent Assignee see page 28																																																																								
	COUNTRY COUNT: 6																																																																									
	PATENT INFORMATION:																																																																									
Patent Family (Basic & Equivalent)	<table border="1"> <thead> <tr> <th>PATENT NO</th> <th>KIND</th> <th>DATE</th> <th>WEEK</th> <th>LA</th> <th>PG</th> <th>MAIN</th> <th>IPC</th> </tr> </thead> <tbody> <tr> <td>DE----29821129</td> <td>U1</td> <td>19990121</td> <td>(199909)*</td> <td>DE</td> <td>15 [9]</td> <td>A63B-53/00</td> <td></td> </tr> <tr> <td>ZA----9810294</td> <td>A</td> <td>19990331</td> <td>(199918)</td> <td>EN</td> <td>15</td> <td>A63B-0/00</td> <td></td> </tr> <tr> <td>GB-----2331939</td> <td>A</td> <td>19990609</td> <td>(199925)</td> <td>EN</td> <td></td> <td>A63B-53/02</td> <td></td> </tr> <tr> <td>FR-----2771936</td> <td>A1</td> <td>19990611</td> <td>(199930)</td> <td>FR</td> <td></td> <td>A63B-53/04</td> <td></td> </tr> <tr> <td>JP-----11221302</td> <td>A</td> <td>19990817</td> <td>(199943)</td> <td>JA</td> <td>6</td> <td>A63B-53/02</td> <td></td> </tr> <tr> <td>CA-----2254184</td> <td>A1</td> <td>19990604</td> <td>(199947)</td> <td>EN</td> <td></td> <td>A63B-53/04</td> <td></td> </tr> <tr> <td>GB-----2331939</td> <td>B</td> <td>20020227</td> <td>(200215)</td> <td>EN</td> <td></td> <td>A63B-53/02</td> <td></td> </tr> <tr> <td>CA-----2254184</td> <td>C</td> <td>20020625</td> <td>(200252)</td> <td>EN</td> <td></td> <td>A63B-53/04</td> <td></td> </tr> </tbody> </table>	PATENT NO	KIND	DATE	WEEK	LA	PG	MAIN	IPC	DE----29821129	U1	19990121	(199909)*	DE	15 [9]	A63B-53/00		ZA----9810294	A	19990331	(199918)	EN	15	A63B-0/00		GB-----2331939	A	19990609	(199925)	EN		A63B-53/02		FR-----2771936	A1	19990611	(199930)	FR		A63B-53/04		JP-----11221302	A	19990817	(199943)	JA	6	A63B-53/02		CA-----2254184	A1	19990604	(199947)	EN		A63B-53/04		GB-----2331939	B	20020227	(200215)	EN		A63B-53/02		CA-----2254184	C	20020625	(200252)	EN		A63B-53/04		DWPI Update see page 31
PATENT NO	KIND	DATE	WEEK	LA	PG	MAIN	IPC																																																																			
DE----29821129	U1	19990121	(199909)*	DE	15 [9]	A63B-53/00																																																																				
ZA----9810294	A	19990331	(199918)	EN	15	A63B-0/00																																																																				
GB-----2331939	A	19990609	(199925)	EN		A63B-53/02																																																																				
FR-----2771936	A1	19990611	(199930)	FR		A63B-53/04																																																																				
JP-----11221302	A	19990817	(199943)	JA	6	A63B-53/02																																																																				
CA-----2254184	A1	19990604	(199947)	EN		A63B-53/04																																																																				
GB-----2331939	B	20020227	(200215)	EN		A63B-53/02																																																																				
CA-----2254184	C	20020625	(200252)	EN		A63B-53/04																																																																				

APPLICATION DETAILS:

PATENT NO	KIND	APPLICATION	DATE
DE----29821129	U1	1998DE-200021129	19981125
ZA-----9810294	A	1998ZA-000010294	19981111
GB-----2331939	A	1998GB-000024977	19981113
FR-----2771936	A1	1998FR-000014903	19981126
JP----11221302	A	1998JP-000343098	19981202
CA-----2254184	A1	1998CA-002254184	19981117
GB-----2331939	B	1998GB-000024977	19981113
CA-----2254184	C	1998CA-002254184	19981117

Application Data
see page 21

DWPI Country Kind Code
see page 58

Priority Data
see page 21

PRIORITY APPLN. INFO: 1997US-000985008 19971204
 INT. PATENT CLASSIF.:
 MAIN: A63B000-00; A63B053-00; A63B053-02; A63B053-04
 GRAPHIC INFORMATION:

International Patent Classification
see page 44

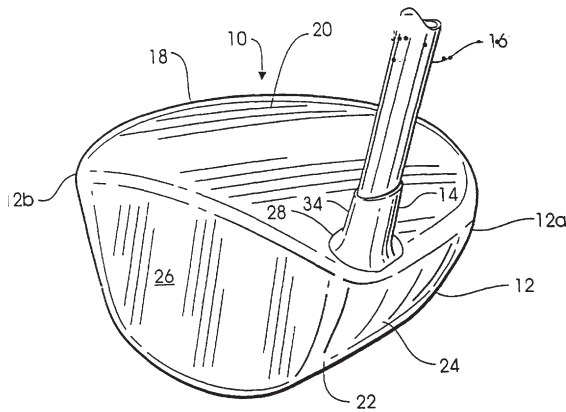

Available Drawing(s)
see page 14

BASIC ABSTRACT:

DE 29821129 U1 UPAB: 20050520

The club head (12) comprises a first material with high elasticity torsion modulus. It has a hollow body (18) with a hitting face (26), a heel end (12a) and a toe end (12b). The head also has a bore (28) in the heel end behind the end face (26) of the body. The bore has an open top end and a closed lower end. The top end is aligned with the top wall (20) of the body.

The neck (14) comprises a second material with low elasticity torsion modulus. It has a lower part fitted into the bore, and an upper part (34) extending away from the top body wall. The neck also has a continuous long passage, and a shaft (16) is fitted into the passage with a pointed end.

The head is of titanium, the neck is of plastic, and the shaft is of graphite.

ADVANTAGE - The neck absorbs vibrations to reduce damage to the shaft.

FILE SEGEMENT: GMPI

DWPI value-added abstract
see page 35

**Member Patent Record
Original Data**

Original Title
see page 35

**International Patent
Classification**
see page 44

Original Main Claim
see page 35

Member(0001)

PI DE----29821129 U1 19990121 (199909)* DE 15[9] A63B-53/00

TIDE Golfschlaeger mit Titankopf und Kunststoffhose

AG AG.T Rechtsanwalt und Patentanwalt Dr.-Ing. Dr.jur.
Volkmar Tetzner, Patentanwalt Dipl.-Ing. Michael Tetzner,
81479 Muenchen

PA (KARS-N) KARSTEN MFG CORP

ADT DE----29821129 U1 1998DE-200021129 19981125

APTS 1998DE-200021129

PRAI 1997US-000985008 19971204

PRTS 1997US-000985008

IC ICM A63B053-00

ICS A63B053-02; A63B053-04

IIC IICM A63B053-00

IICS A63B053-02; A63B053-04

CLMDE 1. Golfschlaeger (10), enthaltend einen Schlaegerkopf (12), der aus einem ersten Material mit hohem Elastizitaets-Torsionsmodulus besteht, wobei der Schlaegerkopf (12) einen hohlen Koerper (18) besitzt mit einer oberen Wand (20), einer unteren Wand (22), einer die obere Wand (20) und die untere Wand (22) verbindende Seitenwand (24) und einer zum Schlagen eines Golfballes angeordneten Stirnwand (26), wobei der Schlaegerkopf (12) ferner ein fersenseitiges Ende (12a) und ein spitzenseitiges Ende (12b) aufweist; wobei ferner der Schlaegerkopf (12) eine in seinem fersenseitigen Ende (12a) hinter der Stirnwand (26) des Koerpers (18) angeordnete Bohrung (28) aufweist, die sich nach unten von der oberen Wand (20) des Koerpers (18) zur unteren Wand (22) des Koerpers (18) erstreckt, wobei die Bohrung (28) ein offenes oberes Ende (28a) und ein geschlossenes unteres Ende (28b) besitzt, wobei weiterhin das obere Ende (28a) der Bohrung (28) im wesentlichen mit der oberen Wand (20) des Koerpers (18) fluchtet und wobei das untere Ende (28b) der Bohrung (28) beabstandet zur unteren Wand (22) des Koerpers (18) angeordnet ist; einen Hosel (14) bestehend aus einem zweiten Material mit niedrigem Elastizitaets-Torsionsmodulus, wobei der Hosel (14) einen in die Bohrung (28) eingefuehrten unteren Abschnitt (36) und einen oberen Abschnitt (34) aufweist, der sich nach oben von der oberen Wand (20) des Koerpers (18) weg erstreckt, wobei der Hosel (14) ferner einen im wesentlichen laenglichen Durchgang (40) besitzt, der sich durch den oberen Abschnitt (34) und den unteren Abschnitt (36) des Hosels (14) hindurch erstreckt; und einen Schaft (16) mit einem im Hoseldurchgang (40) aufgenommenen, spitzenseitigen Ende (17).

**Displaying Member
patent information**
see page 14

Agent Information
see page 29

Records from 1999 onwards (for records until 1999, please see pages 5-6).

ACCESSION NUMBER: 2005-605247 [62] WPIX
 ENTRY DATE: 20051223
 CROSS REFERENCE: 2005-605246
 DOC. NO. CPI: C2005-182208 [62]
 TITLE: Medicament useful for the treatment and prophylaxis of cancer, bone disorder, Morbus Alzheimer comprises at least one substituted pyrazoline compound
 DERWENT CLASS: B03; C02
 INVENTOR: CUBERES ALTISEN R; FRIGOLA CONSTANSA J; GUTIERREZ SILVA B
 PATENT ASSIGNEE: (LDEV-C) LAB DEL ESTEVE SA
 COUNTRY COUNT: 107

DWPI Title
see page 35

DWPI enhanced value-added record

Displaying DWPI information
see page 14

Accession Number
see page 33

DWPI Classification
see page 40

Inventor
see page 26

Patent Assignee
see page 28

PATENT INFORMATION:

PATENT NO	KIND	DATE	WEEK	LA	PG	MAIN	IPC
WO-2005077911	A1	20050825	(200562)*	EN	94 [2]	C07D	-231/06
EP----1626963	A1	20060222	(200615)	EN			

Patent Family (Basic & Equivalent)

DWPI Country Kind Codes
see page 58

APPLICATION DETAILS:

PATENT NO	KIND	APPLICATION	DATE
WO-2005077911	A1	2005WO-EP0001659	20050216
EP----1626963	A1	2005EP-000707485	20050216
EP----1626963	A1	2005WO-EP0001659	20050216

Application Data
see page 21

DWPI Update/Year
see page 31

FILING DETAILS:

PATENT NO	KIND	PATENT NO
EP----1626963	A1	Based on WO-2005077911 A

PRIORITY APPLN. INFO: 2004US-000804534 20040319
 2004ES-000000378 20040217

Priority Data
see page 21

INT. PATENT CLASSIF.:

MAIN: C07D231-06
 SECONDARY: A61K031-415; A61P025-30; A61P003-04;
 A61P035-00
 IPCI A61K0031-415 [I,A]; C07D0231-06 [I,A];
 A61P0025-30 [I,A]; A61P0003-04 [I,A];
 A61P0035-00 [I,A]

International Patent Classification
see page 40

BASIC ABSTRACT:

WO 2005077911 A1 UPAB: 20051223

NOVELTY - A medicament comprises at least one substituted pyrazoline compound optionally in the form of one of the stereoisomers (preferably enantiomers or diastereomers), a racemate or mixture of at least two of the stereoisomers (preferably enantiomers and diastereomers) in any mixing ratio or its corresponding N-oxide or salt, solvate and excipient).

Novelty
see page 35

DETAILED DESCRIPTION - A medicament comprises at least one substituted pyrazoline compound of formula (I) optionally in the form of one of the stereoisomers (preferably enantiomers or diastereomers), a racemate or mixture of at least two of the stereoisomers (preferably enantiomers and diastereomers) in any mixing ratio or its corresponding N-oxide or salt, solvate and excipient).

Detailed Description
see page 35

R1,R2=phenyl (optionally at least mono-substituted);

R3=optionally saturated, optionally at least mono-substituted and optionally containing at least one heteroatom as ring member containing cycloaliphatic group, optionally condensed with an optionally at least mono-substituted mono- or polycyclic ring system); aryl or heteroaryl (both optionally at least mono-substituted, optionally condensed with an optionally at least mono-substituted mono- or polycyclic ring system) or -NR4R5-moiety;

R4,R5=H, T1; an -SO3-R6-moiety or an -NR7R3-moiety;

T1=aliphatic radical (optionally at least mono-substituted and optionally saturated); (optionally at least mono-substituted and optionally saturated, optionally containing at least one heteroatom as ring member containing cycloaliphatic group, which may be condensed with an optionally at least mono-substituted mono- or polycyclic ring system); or aryl or heteroaryl (both optionally at least mono-substituted and optionally condensed with an optionally at least mono-substituted mono-or polycyclic ring system or bonded via a linear or branched alkylene group);

R6=T1;

R7,R8=T1 or H.

Provided that R4 and R5 do not identically represent hydrogen.

INDEPENDENT CLAIMS are included for the following:

(1) a new substituted pyrazoline compound or optionally in the form of one of the stereoisomers (preferably enantiomers or diastereomers), a racemate or mixture of at least two of the stereoisomers (preferably enantiomers and diastereomers) in any mixing ratio or its corresponding N-oxide, salt or solvate (with the provision that R4 and R5 do not both represent a hydrogen atom; and that if one of the residues R4 and R5 represents a hydrogen atom or an alkyl (optionally at least mono-substituted with an alkoxy, alkoxyalkoxy, halogen atom or phenyl group), then the other one the residues R4 and R5 does not represent a pyrid-2-yl group (optionally mono-substituted in the 5-position); pyrid-5-yl group (optionally mono-substituted in the 2-position); pyrimid-5-yl group (optionally mono-substituted in the 2-position); a pyridaz-3-yl group (optionally mono-substituted in the 6-position); pyrazin-5-yl group (optionally mono-substituted in the 2-position); thien-2-yl group (optionally mono-substituted in the 5 position); thien-2-yl group (optionally at least mono-substituted in the 4-position); benzyl group (optionally mono-substituted in the 4-position of the ring); phenethyl group (optionally mono-substituted in the 4-position of the ring); optionally mono-, di- or tri-substituted phenyl group; phenyl group (di-substituted) (where two substituents together form an -OCH2O-, -OCH2CH2O- or -CH2CH2O- chain, which is optionally substituted by halogen atoms or one or two methyl groups); an-NH-phenyl-moiety, (where the phenyl group may be mono-substituted in the 4-position); and

(2) preparation of (I).

ACTIVITY - CNS-Gen.; Cardiovascular-Gen.; Endocrine-Gen.; Respiratory-Gen.; Gastrointestinal-Gen.; Anabolic; Eating-Disorders-Gen.; Immunomodulator; Anorectic; Antidiabetic; Neuroleptic; Antialcoholic; Antiaddictive; Antismoking; Cytostatic; Osteopathic; Dermatological; Tranquilizer; Antidepressant; Anticonvulsant; Neuroprotective; Nootropic; Ophthalmological;

Activity
see page 35

Antimigraine; Vasotropic; Muscular-Gen.; Hemostatic; Hypertensive; Sedative; Antiemetic; Antidiarrheic; Antiasthmatic; Cerebroprotective; Antipruritic; Analgesic; Antibacterial; Antiparkinsonian.

MECHANISM OF ACTION - Cannabinoid receptor (preferably Cannabinoid receptor 1 (CB1)) binder or modulator. An in-vitro determination of the affinity of the N-piperidinyl-5-(4-chlorophenyl)-1-(2,4-dichlorophenyl)-4, 5-dihydro-1H-pyrazole-3-carboxamide (test compound) to CB1-receptor was carried out as described in the publication of Ruth A. Rose, Heather C. Brockie et al., Agonist-inverse agonist characterization at CB1 and CB2 cannabinoid receptors. The radioligand used for both receptors were (3H)-CP55940. The test compound showed % inhibition of 93% at 10⁻⁶ M concentration.

Mechanism of Action
see page 35

USE - For the preparation of medicament for the modulation of cannabinoid-receptors (e.g. cannabinoid 1 (CB1) receptors); for the prophylaxis and treatment of disorders of the central nervous system, disorders of the immune system, disorders of the cardiovascular system, disorders of the endocrinous system, disorders of the respiratory system, disorders of the gastrointestinal tract or reproductive disorders; food intake disorders (e.g. bulimia, anorexia, cachexia, obesity, type 11 diabetes mellitus (non-insuline dependent diabetes mellitus)); psychosis, alcohol abuse and alcohol addiction, nicotine abuse and nicotine addiction, drug abuse and drug addiction and medicament abuse and medicament addiction; cancer (e.g. brain cancer, bone cancer, lip cancer, mouth cancer, esophageal cancer, stomach cancer, liver cancer, bladder cancer, pancreas cancer, ovary cancer, cervical cancer, lung cancer, breast cancer, skin cancer, colon cancer, bowel cancer and prostate cancer); bone disorders (e.g. osteoporosis (such as osteoporosis associated with a genetic predisposition, sex hormone deficiency, or ageing), cancer-associated bone disease or Paget's disease of bone; schizophrenia, anxiety, depression, epilepsy, neurodegenerative disorders, cerebella disorders, spinocerebellar disorders, cognitive disorders, cranial trauma, head trauma, stroke panic attacks, peripheric neuropathy, glaucoma, migraine, Morbus Parkinson, Morbus Huntington, Morbus Alzheimer, Raynaud's disease, tremblement disorders, compulsive disorders, senile dementia, thymic disorders, tardive dyskinesia, bipolar disorders, medicament-induced movement disorders, dystonia, endotoxemic shock, hemorrhagic shock, hypotension, insomnia, immunologic disorders, sclerotic plaques, vomiting, diarrhea, asthma, memory disorders, pruritus, pain, or for potentiation of the analgesic effect of narcotic and non-narcotic analgesics, or for influencing intestinal transit (all claimed).

Use
see page 35

ADVANTAGE - The compounds has a high binding affinity for cannabinoid receptors and suitable for modulating these receptors; act as modulators e.g. antagonists, inverse agonists or agonists on the receptors.

TECHNOLOGY FOCUS:

ORGANIC CHEMISTRY - Preparation (Claimed): Preparation of (I) involves: - (1) process A: reacting at least one benzaldehyde compound formula R1-C(O)-H (II) with pyruvate compound of formula G-C(O)-C(O)-CH3 (III) to obtain a compound of formula R1-CH=CH-C(O)-C(O)-OH (IV) and which is optionally isolated and/or optionally purified; reacting (IV) with an optionally substituted phenyl hydrazine of formula R2-NH-NH2 (V) or it

Technology Focus
see page 35

corresponding salt under inert atmosphere, to obtain a compound of formula (VI) which is optionally isolated and/or optionally purified, and optionally transferred under inert atmosphere to a compound formula (VII) via the reaction with an activating agent which is optionally isolated and/or optionally purified, and then reacting at least one (VI) with a compound R3H (where R3 is an -NR4R5-moiety) under inert atmosphere to obtain (I) (where R3 is -NR4R5-moiety); or - (2) process B: reacting (VII) with a compound R3H under inert atmosphere to yield (I) which is optionally isolated and/or optionally purified. - G=OR pr OK; -

R=1-6C alkyl; - K=cation; - A=leaving group

ABSTRACT, EXTENSION: - Preferred Definitions: - R1=phenyl ring, (mono-substituted with chlorine atom, in its 4-position); - R2=phenyl ring (di-substituted with two chlorine atoms, in its 2-and 4-position); - R3=pyrrolidinyl, piperidinyl, piperazinyl, homo-piperazinyl, morpholinyl, or -NR4R5-moiety; - R4=H, or linear or branched 16C alkyl; - R5=16C alkyl, an-SO2-R6-moiety, pyrrolidinyl, piperidinyl, piperazinyl, homo-piperazinyl, morpholinyl, or triazolyl (where each of the heterocyclic rings optionally substituted by at least one of 16C alkyl); - R6=phenyl (optionally substituted by at least one of 16C alkyl).

ADMINISTRATION - (I) is administered in a daily dosage of 1 - 2000 (preferably 1 - 1500, especially 1 - 1000) mg parenterally (including intramuscularly, intraperitoneally or intravenously), topically, via suppositorily.

SPECIFIC COMPOUNDS - 6 Compounds are specifically claimed as (I) e.g. N-piperidinyl-5-(4-chlorophenyl)-1-(2,4-dichlorophenyl)-4, 5-dihydro-1H-pyrazole-3-carboxamide (IA).

EXAMPLE - In a three neck flask p-chlorobenzaldehyde (13.3 g) and ethyl pyruvate (10 g) were dissolved in absolute ethanol (150 ml). The solution was ice-cooled to 0degreesC and an aqueous solution of NaOH (3.8 g) was added dropwise keeping the temperature less than or equal to 10degreesC, where a yellow-orange colored precipitate was formed. The reaction mixture was stirred for 1 hour at 0degreesC and an additional 1.5 hours at room temperature (approximately 25degreesC). After work up, 4-(4-chlorophenyl)-2-oxo-3-butenic acid (A1) was obtained. (A1) (12.6 g), 2,4-dichlorophenylhydrazine hydrochloride (12.8 g) and glacial acetic acid (200 ml) were mixed under a nitrogen atmosphere and heated to reflux for 4 hours, cooled down to room temperature (approximately 25degreesC) and given into ice-water, where a sticky mass was obtained, which was extracted with methylene chloride. After work up, 5-(4-chlorophenyl)-1-(2,4-dichlorophenyl)-4,5-dihydro-pyrazole-3-carboxylic acid (A2) was obtained. Under nitrogen atmosphere (A2) (2.5 g) was dissolved in thionyl chloride (4 ml) and heated to reflux for 2.5 hours. The excess thionyl chloride was removed from the reaction mixture under reduced pressure and the resulting crude residue (2.6 g) was used without any further purification. After work up, 5-(4-chlorophenyl)-1-(2,4-dichlorophenyl)-4,5-dihydro-pyrazole-3-carboxylic acid chloride (A3) was obtained. Under nitrogen atmosphere N-aminopiperidine (0.6 ml) and triethylamine (4 ml) were dissolved in methylene chloride (25 ml). The resulting mixture was ice-cooled down to 0degreesC and a solution of (A3) in methylene chloride (15 ml) was added dropwise. The resulting reaction

Extension Abstract
see page 35

mixture was stirred at room temperature (approximately 25degreesC) overnight. After work up, N-piperidiny1-5-(4-chlorophenyl)-1-(2,4-dichlorophenyl)-4,5-dihydropyrazole-3-carboxamide was obtained.

Member (0001)

PI WO-2005077911 A1 20050825 (200562)* EN 94[2]
C07D-231/06

TIEN SUBSTITUTED PYRAZOLINE COMPOUNDS, THEIR PREPARATION AND USE AS MEDICAMENTS TIFR COMPOSES DE PYRAZOLINE SUBSTITUEE, PREPARATION ET UTILISATION DE CEUX-CI COMME MEDICAMENTS AG CARVAJAL Y URQUIJO, Isabel
AGA: c/o Clarke, Modet & Co., C/ Goya, 11, E-28001 Madrid, ES

Member Patent Record
Original Data

Displaying Member
Patent Information
see page 14

Original Title
see page 35

Agent Information
see page 29

IN CUBERES ALTISEN R
INO: CUBERES ALTISEN, Rosa
INA: C/Barcelona 2BJ 1D, E-08190 Sant Cugat del Valles, ES

FRIGOLA CONSTANSA J
INO: FRIGOLA CONSTANSA, Jordi
INA: Cami de Can Candeler, 9 B 3.degree.1a, Sant Just Desvern, E-Barcelona, ES

GUTIERREZ SILVA B
INO: GUTIERREZ SILVA, Bonifacio
INA: Rambla Prim 49Bis 7.degree. 4a, E-08019 Barcelona, ES

PA (LDEV-C) LAB DEL ESTEVE SA
PAO: LABORATORIOS DEL DR. ESTEVE S.A.
PAA: Av. Mare de Deu de Montserrat, 221, E-08041 Barcelona, ES
Limitation: except US
Residence: ES
Nationality: ES

Full Inventor Name and
Address
see page 26

-
PAO: CUBERES ALTISEN, Rosa
PAA: C/Barcelona 2BJ 1D, E-08190 Sant Cugat del Valles, ES
Limitation: only US
Residence: ES
Nationality: ES

-
PAO: FRIGOLA CONSTANSA, Jordi
PAA: Cami de Can Candeler, 9 B 3.degree.1a, Sant Just Desvern, E-Barcelona, ES
Limitation: only US
Residence: ES
Nationality: ES

-
PAO: GUTIERREZ SILVA, Bonifacio
PAA: Rambla Prim 49Bis 7.degree. 4a, E-08019 Barcelona, ES
Limitation: only US
Residence: ES
Nationality: ES

ADT WO-2005077911 A1 2005WO-EP0001659 20050216
APTS 2005WO-EP0001659
PRAI 2004ES-000000378 20040217; 2004US-000804534 20040319
PRTS 2004ES-000000378; US2004-000804534
IC ICM C07D231-06
ICS A61K031-415; A61P003-04; A61P025-30; A61P035-00
IIC IICM C07D231-06
IICS A61K031-415; A61P003-04; A61P025-30; A61P035-00

International Patent
Classification
see page 40

Original Abstract
see page 35

ABEN The present invention relates to substitute pyrazoline compounds, methods for their preparation, medicaments comprising these compounds as well as their use for the preparation of a medicament for the treatment of humans and animals.

ABFR L'invention concerne des composes de pyrazoline substituee, des procedes de preparation de ceux-ci, des medicaments comprenant ces composes, ainsi que l'utilisation de ceux-ci dans la preparation d'un medicament destine au traitement d'etres humains et d'animaux.

STN Basic Searching Techniques

Basic STN Commands

FILE	FILE:	Use this command to access <i>Derwent World Patents Index</i> . E.g. file wpindex
E	EXPAND:	Use this command to view an alphabetical or numerical list of terms similar to your search term. E.g. e ford motor/pa e ep 123456/pn
S	SEARCH:	Use to search a keyword, phrase, or field of information. E.g. s ep 123456/pn
D	DISPLAY:	Use to display search results on your computer screen. Complete command: D Answer Set number Format name Item number(s) E.g. d L3 iallg 1-5
D HIS	DISPLAY HISTORY:	This command will display a list of previous search statements.
LOGOFF Y		Disconnects you from STN.

TIP

You can use either the full or abbreviated command when searching.

Truncation

?	The question mark is placed at the end of a search term. This will retrieve all items that contain the stem plus any variations. E.g. s manag? This will retrieve manage, managing, manager. Please Note: Simultaneous left and right handed truncation is available. The truncated stem must be at least 4 characters long. E.g. s ?sulph? This will retrieve terms such as benzoesulphonates.
#	The # sign looks for the stem alone or with one additional character. E.g. s color# This will retrieve color and colors. Please Note: Multiple use of # is also possible to retrieve a maximum number of additional characters equal to the number of #. E.g. s plant### This will retrieve plant, plants, planters, planting but not plantation.
!	The exclamation mark is placed within or at the end of a search term. E.g. s dis!s This will retrieve discs and disks. E.g. s sulph!!! This will retrieve sulphide and sulphate.

TIP

SET PLURALS ON This command automatically retrieves plural forms of singular words when searching by keywords.

TIP

Use the NOT operator with caution as it may remove useful records from your search.

Combining Search Terms

OR	At least one of the search terms must appear in a record, useful for synonyms. E.g. s sun or moon or star
AND	BOTH terms must appear in the same record. E.g. s cat and dog
NOT	You DO NOT want the second term to appear in the record. E.g. s beverage not beer

Proximity Operators

(W)	WITH:	Terms must be in the exact order specified. Please Note: This is the default operator on STN. If no proximity operator is given, a space is interpreted by STN as the (W) operator in the Basic Index and many other fields. E.g. s hard (w) disk s hard disk
(xW)	xWITH:	Terms must be in the exact order specified within (x) number of words from one another. E.g. s online (3w) searching
(A)	ADJACENT:	Terms can be in any order. E.g. s rock (a) climb
(xA)	xADJACENT:	Terms can be in any order within (x) number of words. E.g. s automatic (2a) drill
(xS)	SENTENCE:	Terms must occur in the same sentence in any order. E.g. s telephone (s) portable Please Note: The meaning of "sentence" depends on the search field.

Displaying *DWPI* Information

Popular predefined formats for displaying *DWPI* records are listed below. To view the *DWPI* records, use the DISPLAY command format:

D	L number	Format Name	Item Number(s)
SCAN		Displays enhanced title and accession number (records displayed in random order)	
TRIAL		Displays enhanced title terms, accession number and patent classification information	
TI,AN,GI		Displays enhanced title, accession number, and graphic image	
IBRIEF		Displays indented enhanced title and Basic **abstract	
BASIC		Displays Basic **patent information and Basic **abstract	
IALLG		Displays full enhanced indented record with extended patent family, partial subscriber* coding, and graphic image	
MAXG		Displays full enhanced record with complete subscriber* coding, and graphic image	
IMAXG		Displays full enhanced indented record with complete subscriber* coding, and graphic image	
SUM		Displays enhanced title, accession number and novelty	
FULL		Displays full enhanced record without subscriber coding	
MEMB		Displays all additional member patent information including original abstracts, titles and claims	
MEMBB		Displays patent numbers, enhanced title, original titles, abstracts and claims, and member patent bibliographic information	

TIP

Records display in random order using the SCAN format.

TIP

Indented formats display field descriptions. Useful if you are circulating your search results.

Examples using the DISPLAY command:

=> d L1 trial 1-10

This will display L1 using the TRIAL format for records 1 through 10.

=> d L2 iallg 1-5,20,100

This will display L2 using the IALLG format for records 1 through 5 & 20 & 100.

=> d L2 maxg 10,15,50

This will display L2 using the MAXG format for records 10 & 15 & 50.

** For a definition of "Basic," see page 68, Glossary of Patent Terminology.

* You must have a special agreement with Thomson Scientific in order to access the subscriber coding. For more information, please contact your local Thomson Scientific Support Center.

Sample Search

TIP
GI/FA will narrow your answer set to only those records containing images.

```
=> file wpindex
COPYRIGHT (C) 2006 THE THOMSON CORPORATION

=> s automobile# or (car or cars)
          98293  AUTOMOBILE#
          156590  CAR
          34786  CARS

L1          265497  AUTOMOBILE# OR (CAR OR CARS)

=> s L1 and gi/fa
          8051533  GI/FA

L2          164139  L1 AND GI/FA
```

Patent/Publication Number Searching

Step 1

Enter File WPINDEX to access *Derwent World Patents Index*.

```
=> file wpindex
COPYRIGHT (C) 2006 THE THOMSON CORPORATION
```

Step 2a

Search for a Patent/Publication Number that does not include the publication year.

```
=> s ep 234/pn

L1                1      EP  234/PN
                   (EP234/PN)
```

Step 2b

Search for a Patent/Publication Number that includes a publication year based on 19xx and has a five-digit serial number. If there are less than five digits, backfill with zeros.

```
=> s at 8500819/pn

L2                1      AT  8500819/PN
                   (AT8500819/PN)
```

Step 2c

Search for a Patent/Publication Number that includes a publication year based on 20xx and has a six-digit serial number. If there are less than six digits, backfill with zeros.

```
=> s au 2004212605/pn

L3                1      AU  2004212605/PN
                   (AU2004212605/PN)
```

Please Note: all PCT patent numbers have been converted to a four digit year irrespective of publication date.

Step 2d

Search for a Patent/Publication Number that has a seven-twelve digit serial number.

```
=> s us 5123456/pn

L4                1      US  5123456/PN
                   (US5123456/PN)
```

TIP

If you are unsure of the Patent/Publication Number format, use the Expand (E) command to verify that you are using the correct format.

Example:

```
=> e ep 234/pn
```

Ref	Items	Index-term
E1	1	EP233998/PN
E2	1	EP233999/PN
E3	1→	EP234/PN
E4	1	EP2340/PN
E5	1	EP23400/PN

```
=> s e3
```

Step 3

Display your search results using the Display (D) command. See page 14, Displaying *DWPI* Information.

```
=> d 14 bib 1
L5      ANSWER 1 OF 1 WPINDEX COPYRIGHT 2006 THE THOMSON CORP on STN
AN      1992-116338 [15]      WPINDEX
DNN     N1992-086992 [21]
TI      Hand banding tool which tensions and clamps band and cuts
        off tail - has handle containing mechanism with pivot
        lever operated action for gripping and tensioning band and
        crimping lock buckle with tail cut-off
DC      P52; P62; Q31
IN      JANSEN G A
PA      (BAND-N) BAND-IT-IDEX INC
CYC     4
PIA     EP-----479623      A      19920408      (199215)* EN      18[8]
        US-----5123456      A      19920623      (199228) EN      18
ADT     EP-----479623      A      1991EP-000309148      19911004;
        US-----5123456      A      1990US-000593124      19901005
PRAI    1990US-000593124      19901005
```

Japanese Publication Number Searching

Step 1

The first step towards successfully working with Japanese Patent/Publication Numbers in *DWPI* requires an understanding of the Japanese Imperial Year.

The Imperial Year returns to 1 when a new Japanese emperor ascends the throne of Japan. Hirohito became Japan's emperor in Western Year 1926 and the Imperial Year was therefore reset to 1. To convert from Western Year to Imperial Year and vice versa, you would **ADD** or **SUBTRACT** 1925. When Emperor Hirohito died on January 9, 1989, his son Akihito became the new Japanese emperor and the Imperial Year was again reset to 1. To convert from Imperial Year to Western Year and vice versa, from 1989 onward, you now **ADD** or **SUBTRACT** 1988.

Use the following chart to help you convert from Western Year to Imperial Year and vice versa.

Emperor	Type of document		
	Kokai (JP-A)	Kokoku (JP-B) until 29 th May 1996	Toroku/Tokkyo Koho (JP-B) from 29 th May 1996
Hirohito until 1989	JPYYNNNNNN YY = Year of the Emperor = Western Year – 1925 (2 digits) e.g. JP57023687	JPYYNNNNNN YY = Western Year (2 digits) = Year of the Emperor + 1925 (2 digits) e.g. JP86011279	
Akihito until 2000	JPYYNNNNNN YY = Year of the Emperor = Western Year – 1988 (2 digits) e.g. JP07195490	JPYYNNNNNN YY = Western Year (2 digits) = Year of the Emperor + 1988 (2 digits) e.g. JP95122126	Numbered sequentially starting from 2500001 e.g. JP2787065B
Akihito from 2000	JPYYYYNNNNNN YY = Western Year (4 digits) e.g. JP20000154938	Discontinued	Numbered sequentially

TIP

On STN you can also search Kokoku documents using the Emperor year but you must include the B status code as part of the patent number to avoid potential clashes with pre-2000 Kokaki documents.

e.g. **sjp86011279/pn**
sjp61011279b/pn

TIP

You must include the B status code as part of the patent number when searching Toroku or Tokkyo Koho documents.

e.g. **s jp2787065B/pn**

Examples of the conversion process:

Convert the Western Year 1986 to Imperial Year.	1986 SUBTRACT 1925	= 61
Convert the Western Year 1992 to Imperial Year.	1992 SUBTRACT 1988	= 4
Convert the Imperial Year 57 to Western Year.	57 ADD 1925	= 1982
Convert the Imperial Year 5 to Western Year.	5 ADD 1988	= 1993

Step 2

Determine which type of Patent/Publication Number to use.

Kokai These are unexamined applications that have been published. These publications are easily recognized in *DWPI* by the Kind Code A following the publication number. To search for Kokai publications you must use the Imperial Year for documents issued before 1st January 2000 and the Western Year for documents issued after 1st January 2000.

Kokoku These documents are examined and accepted publications. They are distinguished by the Kind Code B. When searching for Kokoku documents in *DWPI*, you should use the Western Year. The Kokoku were replaced by new law Toroku documents in May 1996.

Toroku/Tokkyo Koho

DWPI coverage started mid-1996. These granted patents have a continuous serial number starting at 2,500,000 and have a kind code of B2 (Toroku) if they were previously published at the Kokai stage or B1 (Tokkyo Koho) if they were not previously published at the Kokai stage. Search for these just as you would search for a US Patent Number but include the B status code as part of the patent number (see page 16 Patent/Publication Number Searching).

Step 3

Lastly, conduct your search using the following format

S JP YYNNNNNN/PN

Sample Search 1 : Japanese Kokai from 1984 with serial number 2345.

- 1 Convert the Western Year (1984) to the Imperial Year.
1984 Subtract 1925 = Imperial year 59
- 2 Insert the Imperial Year into the publication number format.
S jp 59NNNNNN/PN
- 3 Add the serial number. If less than six digits, insert leading zeros.
s jp 59002345/PN

Sample Search 2: Find the following Japanese Kokoku publication number: JP 5/123 B

- 1 Convert the Imperial Year (5) to the Western Year.
5 Add 1988 = Western Year 1993
- 2 Insert the Western year into the publication number format.
S jp 93NNNNNN/PN
- 3 Add the serial number to the publication format. Since three digits are missing, back-fill with zeros.
s jp 93000123/PN

Alternatively on STN you can search the number as it originally appeared,
e.g. **s jp 05000123 b/pn**

Sample Search 3: Find the following Japanese Toroku publication number JP2509927 B2

- 1 Retain the format shown above
s jp2509927B2/PN

Since the publication year is not included in the patent number there is no need to convert any part of the number before you search it but you must include the B status code.

TIP

If you do not find the record you are looking for use the EXPAND command.

Application/Priority Number Searching

TIP

If you do not find the record that you are looking for, use the Expand command:
e 1992jp-4512/ap

Step 1

Enter File WPINDEX to access *Derwent World Patents Index*.

```
=> file wpindex
COPYRIGHT (C) 2006 THE THOMSON CORPORATION
```

Step 2a

Search for Application Numbers using the following format: S YYYYCC-XXXXXXXX/AP or YYYYCC-XXXXXXXXXXXX where X represents a digit or letter. For missing digits, there is NO need to backfill with zeros.

```
=> s 1992jp-4512/ap
L1          1          1992JP-4512/AP
                    (JP1992-4512/AP)
```

TIP

All Japanese Application Numbers are searched using the Western Year
s 1992jp-4512/ap

Step 2b

Search for Priority Numbers using the following format: S YYYYCC-XXXXXXXX/AP or YYYYCC-XXXXXXXXXXXX where X represents a digit or letter. For missing digits, there is NO need to backfill with zeros.

```
=> s 1979us-623/prn
L2          1          1979US-623/PRN
                    (US1979-623/PRN)
```

Step 2c

Use the /APPS search field to search both the Application and Priority numbers simultaneously.

```
=> s 1998wo-jp1501/apps
                    1          WO1998-JP1501/AP
                    1          WO1998-JP1501/PRN
L3          1          1998WO-JP1501/APPS
                    (WO1998-JP1501/AP, PRN)
```

Step 3

Display search results using the Display (D) command. See page 14, Displaying *DWPI* Information.

```
=> d L3 basic 1

L3 ANSWER 1 OF 1 WPINDEX COPYRIGHT 2006 THE THOMSON CORP on STN
AN 1999-580844 [49] WPINDEX
DNN N1999-428821 [49]
TI Shield mask for glasses
DC P81
IN PREUTZ S
PA (POLA-N) POLARIS INTER AB
PNC 2
CYC 20
PI WO--1999050705 A1 19991007 (199949)* JA 24[6] G02C-007/10
ADT WO--1999050705 A1 1998WO-JP0001501 19980401
PRAI1998WO-JP0001501 19980401
AB WO 1999050705 A1 UPAB: 20050523
    NOVELTY - The shield mask includes including a frame
    integrally having portions having the functions of lens brim
    portions, a bridge portion and a temple portion, a shield
    encircled by the frame for protecting the eyes, and
    acceptance portion for accepting fitting of nose pads or
    refracting glasses at the bridge portion of the frame. The
    acceptance portion includes two opposed brackets having
    recess portions disposed inside the center portion of the
    shield mask or two opposed plates having holes. Glasses
    equipped with the nose pads are fitted to the shield mask,
    and include at least two rod-like parts fitted into the
    holes and spring-like clamps for pressing the two rod-like
    parts with a necessary and sufficient press force from the
    transverse direction of the recess portions of the bracket
    or for fitting and removing the rod-like parts into and from
    the holes from the transverse direction of the plate.
    USE - For glasses.
    ADVANTAGE - The mask is capable of being easily fitted
    to, and removed from, refracting glasses, protects the
    mounted glasses, and acts as a pair of sunglasses, giving
    excellent fashionability.
    DESCRIPTION OF DRAWINGS - The drawing shows a diagram to
    illustrate the shield mask.
FS GMPI
```

Step 4

If more than one Priority Number is in the record or if a Cross Reference Number exists, see pages 23-25, Complete Patent Family Searching.

Complete Patent Family Searching

Find the complete patent family for US 4000000

Step 1

Enter File WPINDEX to access *Derwent World Patents Index*.

```
=> file wpindex
COPYRIGHT (C) 2006 THE THOMSON CORPORATION
```

Step 2

Conduct an effective Patent/Publication Number search. See page 16, Patent/Publication Number Searching.

```
=> s us 4000000/pn
L1          1          US  4000000/PN
                    (US4000000/PN)
```

Step 3

Display your search results using the Display (D) command. See page 14, Displaying *DWPI* Information.

```
=> d L1 trial,prai 1
L1 ANSWER 1 OF 1 WPINDEX COPYRIGHT 2006 THE THOMSON CORP on STN
AN 1975-81520W [50] WPIDS
TT TT: ASPHALT AGGREGATE MIXTURE MANUFACTURE PREFER RECOVER ROAD
   SURFACE MATERIAL
DC L02 P64 Q41
IC B01F003-14; B01F009-02; C08J003-18; C08K005-01;
   C10C000-00; E01C019-10; E01C023-14
MC CPI: L02-D10
PNC 13
CYC 9
PRAI 1972US-000286613 19720905; 1972US-000286618 19720905;
     1973US-000360464 19730515; 1974US-000360464 19740515;
     1974US-000488518 19740715; 1975US-000601176 19750801;
     1975US-000601177 19750801; 1976US-000697322 19760830;
     1977US-000758316 19770110; 1974GB-000035597 19740813
```

Step 4

Examine the *DWPI* record. If the record contains a Cross Reference Number (CR)

OR

Contains MORE than ONE Priority Number, You MUST conduct a complete patent family search.

Step 5

Conduct a complete patent family search using the FSEARCH command followed by a publication number from the target record. FSEARCH is useful to AUTOMATICALLY locate all *DWPI* records relating to the same invention. FSEARCH accomplishes this task by automatically extracting all Patent/Publication Numbers, Application Numbers, and Priority Numbers and searching these numbers in *DWPI* to see if there are any interrelated records.

```
=> fsearch us 4000000/pn
SEA  US 4000000/PN
L2      1      US 4000000/PN
                               (US4000000/PN)

FSE
*** ITERATION 1 ***
SET SMARTSELECT ON
SET COMMAND COMPLETED
SET HIGHLIGHTING OFF
SET COMMAND COMPLETED
SET AUDIT OFF
SET COMMAND COMPLETED
```

Step 6

If the number of *DWPI* records retrieved in L4 is the same number that was retrieved after Iteration 2, FSEARCH will stop and you will have the Complete Patent Family. If the number increases, FSEARCH will continue searching.

```
SEL L2 1- PN,APPS
L3SEL L2 1- PN APPS : 23 TERMS

SEA L3
L4      8      L3

*** ITERATION 2 ***

SEL L4 1- PN,APPS
L3SEL L2 1- PN APPS : 46 TERMS
```

```

SEA L3
L4      8      L3

FSORT L4
L5      8      FSO L5
          1      Multi-record Family Answers 1-8
          0      Individual Records
          0      Non-patent Records

SET SMARTSELECT OFF
SET COMMAND COMPLETED
SET HIGHLIGHTING DEF
SET COMMAND COMPLETED
SET AUDIT ON
SET COMMAND COMPLETED

```

Step 7

Display your search results using the Display (D) command. See page 14, Displaying *DWPI* Information.

```

=> d L5 trial,prai 1-2

L5 ANSWER 1 OF 8 WPIDS COPYRIGHT 2006 THE THOMSON CORP on STN FAMILY 1
AN 1981-25189D [14] WPIDS
TT TT: LIQUID ASPHALT COMPOSITION ADD ASPHALT AGGREGATE RECYCLE
    COMPOSITION COMPRISE ASPHALT PETROL HYDROCARBON
DC L02
IC C08J003-18; C08L095-00
MC CPI: L02-D10
PNC 1
CYC 1
PRAI 1974US-000488518 19740715; 1976US-000734292 19761020

L5 ANSWER 2 OF 8 WPIDS COPYRIGHT 2006 THE THOMSON CORP on STN FAMILY 1
AN 1979-B2977B [06] WPIDS
TT TT: ASPHALT AGGREGATE SLEEVE MIX SLEEVE EXTEND ROTATING DRUM
    DEFINE FINAL MIX CHAMBER
DC P64
IC B28C005-06
PNC 1
CYC 1
PRAI 1974US-000488518 19740715; 1975US-000601177 19750801;
    1975US-000616910 19750926; 1977US-000758316 19770110

```

Inventor Searching

Find all the patents in *DWPI* for which G.E. Wright is the inventor

Step 1

Enter File WPINDEX to access *Derwent World Patents Index*.

```
=> file wpindex
COPYRIGHT (C) 2006 THE THOMSON CORPORATION
```

Step 2

Use the Expand (E) command to help identify inventors. The Expand command will show all items in the *DWPI* index that are alphabetically similar to the inventor's last name, first initial, and middle initial (if known). It also shows the number of hits for each item.

```
=> e wright g/in
E1          12      WRIGHT F W/IN
E2           1      WRIGHT FREEMAN M/IN
E3          70 ->   WRIGHT G/IN
E4          50      WRIGHT G A/IN
E5           9      WRIGHT G B/IN
E6          33      WRIGHT G C/IN
E7           4      WRIGHT G D/IN
E8          20      WRIGHT G E/IN
E9           3      WRIGHT G E R/IN
E10          4      WRIGHT G F/IN
E11          1      WRIGHT G G/IN
E12          9      WRIGHT G H/IN
```

TIP

If you do not find the inventor(s) names that you are looking for, search for the named individual(s) in the Patent Assignee field (see page 28, Assignee/Company searching).

Step 3

Select all the appropriate inventor(s) from the Expand list.

```
=> s e3,e8,e9
          25      "WRIGHT G"/IN
           6      "WRIGHT G E"/IN
           3      "WRIGHT G E R"/IN
L1        91      ("WRIGHT G"/IN OR "WRIGHT G E"/IN OR
                  "WRIGHT G E R"/IN)
```

Step 4

Display your search results using the Display (D) command. See page 14, Displaying *DWPI* Information.

```
=> d L1 bib 1
L1 ANSWER 1 OF 91 WPINDEX COPYRIGHT 2006 THE THOMSON CORP on STN
AN 2006-065462 [07] WPINDEX
DNN N2006-056896
TI Service mediation providing apparatus in network, has multi
protocol label switching mediation edge device that resolves
associations between layer-2 edge devices and multi protocol
label switching provider edge device.
DC W01
IN HACHE, E; OULD-BRAHIM, H; SUGIMOTO, J; WRIGHT, G
PA (NELE) NORTEL NETWORKS LTD
CYC 111
PI US-2005286558 A1 20051229 (200607)* 12
WO-2006000100 A1 20060105 (200607) EN
ADT US--2005286558A1 Provisional 2004US-000583381P 20040628,
2005US-000167883 20050627; WO--2006000100 A1 2005WO-CA0001006
20050628
PRAI 2004US-000583381P 20040628; 2005US-000167883 20050627
```

Step 5

If you know the full name of the inventor then you could also consider using the Expand (E) command on the Inventor Full Name index (/IN.T) to narrow your search to relevant answers.

The Inventor Full Name index (/IN.T) is based on original, non-standardized bibliographic data. Due to the wide variation of formatting and punctuation of original inventor full names it is necessary to expand the index in various ways to ensure that all relevant data is considered.

TIP

Due to the limited coverage and wide variation in formatting of Full Inventor Names the /IN.T index should **NOT** be used in isolation of the /IN index when searching for inventors.

```
=> e wright, george/in.t
E1 1 WRIGHT, GEOFFREY, DAVID, GB/IN.T
E2 1 WRIGHT, GEOFFREY, US/IN.T
E3 3 -> WRIGHT, GEORGE/IN.T
E4 1 WRIGHT, GEORGE A., DELAND, FL, US/IN.T
E5 1 WRIGHT, GEORGE A., NJ, US/IN.T
E6 1 WRIGHT, GEORGE B./IN.T
E7 2 WRIGHT, GEORGE B., COLLEGE STATION, TX,
US/IN.T
E8 8 WRIGHT, GEORGE C/IN.T
E9 10 WRIGHT, GEORGE C./IN.T
E10 1 WRIGHT, GEORGE C., NORWICH, N.Y., US/IN.T
E11 23 WRIGHT, GEORGE C., NY, US/IN.T
E12 2 WRIGHT, GEORGE C., WA, US/IN.T
```

```
=> e wright george/in.t
E1 1 WRIGHT GALEN R/IN.T
E2 1 WRIGHT GAVIN/IN.T
E3 1 -> WRIGHT GEORGE/IN.T
E4 1 WRIGHT GRAHAM L/IN.T
E5 1 WRIGHT GRAHAM LESLIE/IN.T
E6 1 WRIGHT GRAHAM S/IN.T
E7 2 WRIGHT GREGORY A/IN.T
E8 15 WRIGHT GREGORY ALAN/IN.T
E9 1 WRIGHT H EARL/IN.T
E10 2 WRIGHT HAL E/IN.T
E11 1 WRIGHT HEATHER/IN.T
E12 1 WRIGHT HENRY L/IN.T
```

Assignee/Company/Agent Searching

Retrieve IBM's patent portfolio

Step 1

Enter File WPINDEX to access *Derwent World Patents Index*.

```
=> file wpindex
COPYRIGHT (C) 2006 THE THOMSON CORPORATION
```

Step 2

Use the Expand (E) command to identify Assignee/Company information.

```
=> e ibm/pa
E1          2      IBLV/PA
E2          2      IBLV-I/PA
E3         26048 -> IBM/PA
E4          1      IBM BRASIL IND MAQU/PA
E5          2      IBM BRASIL IND MAQUINAS & SERVICOS LTDA/
                    PA
E6          1      IBM BUSINESS CONSULTING SERVICES KK/PA
E7          619     IBM CANADA LTD/PA
E8          1      IBM CHINA CO LTD/PA
E9          1      IBM CHINA HONGKONG CO LTD/PA
E10         24046   IBM CORP/PA
E11         678     IBM DEUT GMBH/PA
E12         6      IBM DEUT INFORMATIONS SYSTEME GMBH/PA
```

TIP

To find Patent Assignee codes use the look-up facility on the Thomson Scientific web site www.scientific.thomson.com/support/patents/dwpieref/reftools/companycodes/lookup/

Step 3

Select the third entry (E3) which retrieves all entries that contain the word IBM.

```
=> s e3
L1         26048   IBM/PA
```

TIP

If the company you are looking for does not have its own Patent Assignee Code, then you should omit step 4 site.

Step 4

Search the *DWPI* Patentee Code for IBM. Since corporate names are not standardized, but vary widely according to location and subsidiary, a single company code is assigned to 21,000 patentees that are known to be related and that regularly file a large number of patents. *DWPI* Patentee Codes can be found in the Patentee Codes Manual and on the Thomson Scientific web site Patentee Code Look Up facility.

```
=> s ibmc/paco
L2          63481      IBMC/PACO
                    (IBMC/PACO)
```

Step 5

Use the Expand (E) command to identify agent information. Including the agent field in the search can be useful as US applications are often published without designating a patentee. However this information can sometimes be found in the agent field instead.

The Agent Name index (/AG.T) is based on original, non-standardized bibliographic data. Due to the wide variation of formatting and punctuation of agent information it may be necessary to expand the index in various ways to ensure that all relevant data is considered

Select the third entry (E3) which retrieves all entries that contain the word IBM.

```
=> e ibm/ag.t

E1          1          IBIS TECHNOLOGIES B.V., DRIENERLOLAAN 5,
NL-7522 NB ENSCHEDE , NL/AG.T
E2          1          IBLEERA/AG.T
E3         18678  ->   IBM/AG.T
E4          2          IBM (ROC-BLF), C/O BIGGERS & OHANIAN,
LLP, P.O. BOX 1469, AU STIN, TX, US/AG.T
E5          1          IBM - INTELLECTUAL PROPERTY LAW DEPT.,
8051 CONGRESS AVENUE, BOCA RATON, FL, US/
AG.T
E6          9          IBM COPORATION (RTP), C/O SCHUBERT
OSTERRIEDER & NICKELSON P LLC, 6013
CANNON MOUNTAIN DRIVE, S14, AUSTIN, TX,
US/AG.T
E7          1          IBM COROPORATION, INTELLECTUAL PROPERTY
LAW DEPT. 917, BLDG. 006-1, 3605 HIGHWAY
52 NORTH, ROCHESTER, MN, US/AG.T
E8          40         IBM CORP (AP), C/O AMY PATTILLO, P. O.
BOX 161327, AUSTIN, T X, US/AG.T
E9          66         IBM CORP (BLF), C/O BIGGERS & OHANIAN,
LLP, 504 LAVACA STREET, SUITE 970,
AUSTIN, TX, US/AG.T
E10         19         IBM CORP (JRB), C/O LAW OFFICE OF JOSEPH
R BURWELL, P O BOX 28022, AUSTIN, TX, US/
AG.T
E11         11         IBM CORP (WSM), C/O WINSTEAD SECHREST &
MINICK P.C., PO BOX 50784, DALLAS, TX,
US/AG.T
E12         495        IBM CORP (YA), C/O YEE & ASSOCIATES PC,
P.O. BOX 802333, DALLAS, TX, US/AG.T

=> s e3
L3          18678      IBM/AG.T
```

Step 6

Combine the results from the Expand lists and the Patentee Code using the (OR) command.

```
=> s L1 or L2 or L3
L3          64090          L1 OR L2 or L3
```

Step 7

Use the Display (D) command to display your results. See page 14, Displaying *DWPI* Information.

```
=> d bib 1
L6 ANSWER 1 OF 64090 WPINDEX COPYRIGHT 2006 THE THOMSON CORP on
STN
AN 1999-600945 [51] WPINDEX
DNN N1999-442994 [51]
TI Effective addresses calculation method for logic circuits in
processors
DC T01
IN CIRAULA M K; MARTENS D J
PA (IBMC-C) INT BUSINESS MACHINES CORP
CYC 1
PIA US-----5970512 A 19991019 (199951)* EN 13[5]
ADT US-----5970512 A 1997US-000826174 19970327
PRAI 1997US-000826174 19970327
```

Using Date Ranging, *DWPI* Country Information and *DWPI* Update/Year(s)

Searching for Dates

All dates read Year, Month, Day

TIP

The *DWPI* Basic is the first published patent document received by Thomson Scientific for a given invention. The Basic is not necessarily the priority or first application to publish.

To Search for:	Type:
Publication Date (April 30, 1992)	s 19920430/pd
Publication Year (1996)	s 1996/py
Publication Year Basics*	s 1999/py.b
*This will retrieve only NEW inventions with a publication date of 1999.	
Application Date (June 10, 1989)	s 19890610/ad
Application Year (1989)	s 1989/ay
Priority Application Date (May 27, 1995)	s 19950527/prd

All Publication and Application Dates may be Date Ranged as follows:

Publication Year (1992 to 1994)	s 1992-1994/py
Publication Year Basics (1981 to 1984)	s 1981-1984/py.b

TIP

STN has system limits on the number of records that can be retrieved in a single search. To minimize these limitations, narrow your search before searching on Dates, Country Information or *DWPI* Update/Year(s).
e.g. s L3 and us/pc

Searching for Country Information

To Search for:	Type:
Publication Country	s us/pc
Publication Country and all	
Designated States	s dk/pcs
Designated States	s gb/ds
Publication Country and	
Year	s jp/pc (p) 1997/py
Application Country	s ep/ac
Priority Country	s us/prc

TIP

The STN SET RANGE command allows you to limit a series of searches to a specified portion of *DWPI* e.g. for identifying records added in 1996, 1997, 1998 and 1999.
Setran=(1996-1999)

Searching *DWPI* Update/Year

The *DWPI* year and update are displayed in the Patent Number field following each Patent Family member, indicating the year and update of entry into *DWPI*.

Example:

PATENT NO	KIND	PUB DATE	<i>DWPI</i> UPDATE	LANGUAGE	PAGES
EP-----945362	A1	19990929	(199945)*	DE	4p

To Search for:	Type:
<i>DWPI</i> Update	s 199740/dw
Publication Country within a <i>DWPI</i> update	s wo/pc (p) 199740/dw
A range of <i>DWPI</i> updates	s 199801-199832/dw

Using *DWPI* Update Codes and Accession Numbers

DWPI Update Codes

All data added to *DWPI* is labeled with one or more update codes indicating when it was loaded into the file. The latest update added to *DWPI* can be found in the online banner which is displayed when you connect to *DWPI*.

Example:

```
FILE 'WPINDEX' ENTERED AT 17:06:30 ON 13 JUL 2006
COPYRIGHT (C) 2006 THE THOMSON CORPORATION
FILE LAST UPDATED:          11 JUL 2006          <20060711/UP>
MOST RECENT DERWENT UPDATE: 200644             <200644/DW>
DERWENT WORLD PATENTS INDEX, COVERS 1963 TO DATE
```

The update code represents the exact date (year, month, day) when *DWPI* was updated.

Update codes are very useful if you wish to isolate new or amended records in *DWPI*. They are commonly used for SDIs* to avoid retrieving records already seen in a previous search.

To Search For:	Type:
All new inventions (<i>DWPI</i> Basics**) added to <i>DWPI</i> in file update 20060711	s 20060711/ed
All equivalent** patent documents added to <i>DWPI</i> in June 2006	s june 2006/upeq
All new inventions and equivalents added to <i>DWPI</i> in file update 20060711	s 20060711/upp
All new material added to <i>DWPI</i> in 2006	s 2006/upoa

* An explanation and example of an SDI is given on page 56

** For an explanation of "Basic" see page 68: Glossary of Patent Terms

Searching *DWPI* Accession Number(s)

The *DWPI* Accession Number is a unique serial identification number consisting of the year of entry and a six-digit number that is assigned to all records. The Cross Reference Number (available from 1985 to present) contains the Accession Number(s) of other *DWPI* records that are considered part of the full Patent Family. For more information on Patent Family Searching, see pages 23, Complete Patent Family Searching.

Example:

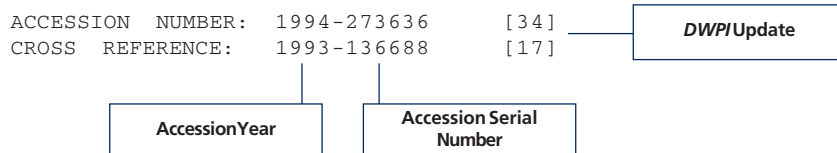

To Search For:

Type:

DWPI Accession Number

s 1994-273636/an

Cross Reference Number

s 1993-136688/cr

Subject/Keyword Searching

Conduct a keyword search on production methods for inks that are used in colour inkjet printers

Step 1

Enter File WPINDEX to access *Derwent World Patents Index*.

```
=> file wpindex
COPYRIGHT (C) 2006 THE THOMSON CORPORATION
```

Step 2

The search terms have been separated by the Adjacent (A) operator to give the search more flexibility (see page 12 for an explanation of the Adjacent (A) operator). The ? truncation symbol will find all the variations of the search term "PRINT".

```
=> s ink (2a) jet (2a) print?
          132273      INK
          121466      JET
          611372      PRINT?
L1        20509      INK (2A) JET (2A) PRINT?
```

Step 3

In this step, we have combined the results of our first set L1 with a Keyword Search on color using the "AND" operator. Notice the use of the British and American spelling for color/colour.

```
=> s L1 and (color# or colour#)
          149346      COLOR#
          291280      COLOUR#
L2        4368       L1 AND (COLOR# OR COLOUR#)
```

Step 4

The results of the second set L2 are combined with a Keyword Search on production. Please note the use of the Thomson Scientific abbreviation for production (prodn). See page 66, Thomson Scientific Standard Abbreviations.

```
=> s L2 and (prodn or production)
          473947      PRODN
          413316      PRODUCTION
L3        307       L2 AND (PRODN OR PRODUCTION)
```

TIP

Both British and American English should be used when searching *DWPI*; further information can be found at www.scientific.thomson.com/support/patents/dwpiref/reftools/usukdict/

TIP

If you type SET PLURALS ON against your ID, STN will automatically search for plurals of any singular terms that you search.

Step 5

Enter the D HIS command to display the search history.

```
=> d his
L1      20509      S INK (2A) JET (2A) PRINT?
L2      4368      S L1 AND (COLOR# OR COLOUR#)
L3      307       S L2 AND (PRODN OR PRODUCTION)
```

TIP

D SCAN will display a random selection of titles free of charge.

Step 6

Display your search results using the Display (D) command. See page 14, Displaying *DWPI* Information.

```
=> d l3 ti
L3      ANSWER 1 OF 307 WPINDEX COPYRIGHT 2006 THE THOMSON CORP on STN
TI      Water dispersion useful for ***ink-jet printing comprises
        colorant-containing water-insoluble polymer particles that are
        obtainable by mixing at least two kinds of water-insoluble
        polymer particles.
```

DWPI Basic Index

All unqualified keywords are automatically searched in the *DWPI* Basic Index. This index consists of the following fields:

TIP

Title Terms are NOT a replacement for proper truncation of search terms.

Title	Rewritten and intellectually enhanced by Thomson Scientific analysts. Search Thomson Scientific titles only by post-qualifying the search term with /ti. E.g. s mouse/ti
Title Terms	Computer generated standardised forms of words appearing in the Thomson Scientific title. The Title Terms User Guide contains a complete list. Useful for finding variations of a word. E.g. s lock STN will retrieve <i>DWPI</i> records containing "lock", "lockable", "locking" etc. in their title.
Additional Words	These words were added by Thomson Scientific to the title terms field between 1978 and 1998 to enhance retrieval.
Abstract(s)	Written and enhanced by Thomson Scientific analysts. Some records will not have abstracts associated with them. See <i>Global Patents Sources</i> for complete information on country coverage within <i>DWPI</i> . To eliminate records that do not have abstracts, use the field availability index. E.g. s L3 and ab/fa
Technology Focus	Supplementary information to the abstract. Search the Thomson Scientific technology focus field only by post-qualifying the search term with /tech. E.g. s chlorine/tech

TIP

Searching of the Documentation and Extension Abstracts is available for all users within the Basic Index. However you must have a valid subscription with Thomson Scientific in order to display these abstract fields.

TIP

Set your STN login ID to automatically retrieve all relevant Thomson Scientific abbreviations for a search term by typing **set abbrev on perm**

Abstract Styles

Pre-1999 records may contain an abstract section called the First Section which was based on the claims together with a Use, Use/Advantage or Advantage section.

In addition records from 1984-1997 may additionally have an abstract for equivalent members of the patent family (Equivalent Abstracts).

From 1995-1999 a Documentation Abstract may also be available which provides greater detail and in-depth analysis of the invention.

In 1999 important changes were made to the structure and content of the abstracts. As well as containing improved technical content, the abstracts now also include several subheadings to make the description of the invention easier to read:

Novelty	Outlines the novelty of the invention.
Detailed Description	Optional paragraph included when it is not possible to summarise the main claims of the invention within the novelty field.
Activity	Used to describe the biological activity of chemical or biological entities.
Mechanism of Action	Covers the biological mechanism of action for chemical or biological entities (where given).
Use	This paragraph is always present, and covers all the uses (applications) of the invention in terms of its different technology areas. If there are no disclosed uses, this is stated.
Advantage	Covers the advantages of the invention as described by the author.
Technology Focus	This field is designed to enable end-user scientists and engineers, in various sectors, to quickly identify if a patent document is of real interest to them. Separate headed paragraphs describe the invention from different technological viewpoints - immediately bringing home the importance of the patent to a variety of disciplines.
Extension Abstract	Providing greater detail and in-depth information, the Extension Abstract field was created to help add further clarity to the Thomson Scientific value-add description of the invention. As such it is of great value to the end user scientist. To facilitate this, the Extension Abstract is written using separate headed paragraphs, so presenting the content in an easily understood way.
Description of Drawing(s)	Explanation of technical drawings included in the record.

Abbreviations

When conducting Subject/Keyword searches in *DWPI*, please refer to the Thomson Scientific list of standard abbreviations as commonly-used terminology may have been abbreviated. See page 66, Thomson Scientific Standard Abbreviations, the Thomson Scientific web site at www.scientific.thomson.com/support/patents/dwpioref/reftools/abbrev/ or type HELP ABBREV at an => prompt. It is very important that you search both the original word and the Thomson Scientific abbreviated form.

Example: **s atmos or atmosphere**

British/American Spellings and Terminology

To conduct a complete Subject/Keyword search, it is extremely important to search British as well as American spellings and terminology.

Some examples:

British	American
Tyre	Tire
Colour	Color
Sulphur	Sulfur
Nappy	Diaper
Torch	Flashlight
Lift	Elevator

More information can be found at www.scientific.thomson.com/support/patents/dwpioref/reftools/usukdict/

DWPI Extended Basic Index

Additional keyword searching capabilities are provided by the Extended Basic Index which conveniently gathers together all available subject words from original titles, abstracts, and claims. The following fields are included in the Extended Basic Index:

Original Title	All words from the original title. Search original titles only by post-qualifying the search term with /tide (German language original titles), /tien (English language original titles), /tifr (French language original titles) or /ties (Spanish language original titles) E.g. s mantel/tide s computer/tien s voiture/tifr s cilindro/ties
Original Abstract	All words from the original abstract (available in German, English, French and Spanish)
Original Claims	All words from the original claims (available in German, English and French).

As the Extended Basic Index is NOT the default search field in *DWPI* the suffix */BIEX* must be used in all Expand and Search commands otherwise the search will default to the standard Basic Index e.g.

```
s (ink (2a) jet (2a) print?)/biex
      61308      INK/BIEX
      55176      JET/BIEX
      203950     PRINT?/BIEX
L1      11868     (INK (2A) JET (2A) PRINT?)/BIEX
```

Using the *DWPI* Classification System

Search for patents on antilock braking systems (ABS) for automobiles and other vehicles

Thomson Scientific categorizes patent documents using a simple classification system for all areas of technology. This unique classification system has been consistently applied to all patent documents by subject specialists at Thomson Scientific since 1970. The *DWPI* Classification provides a uniform and accurate indexing tool that will allow you to effectively clarify ambiguous keywords and broaden or narrow your Subject/Keyword searches. See page 43, Using the *DWPI* Classification System: Sample Page.

Step 1

Enter File WPINDEX to access *Derwent World Patents Index*.

```
=> file wpindex
COPYRIGHT (C) 2006 THE THOMSON CORPORATION
```

Step 2

Begin by searching all the variations of antilock brakes. See pages 35, Subject/Keyword searching.

```
=>s abs or (antilock? or anti(w)lock?) (w) brak?
          19899      ABS
          2699      ANTILOCK?
          228875     ANTI
          392971     LOCK?
          159668     BRAK?
          4542      (ANTILOCK? OR ANTI(W)LOCK?) (W) BRAK?
L1        23015     ABS OR (ANTILOCK? OR ANTI(W)LOCK?) (W)
          BRAK?
```

Step 3

Display your search results using the Display (D) command. See page 14, Displaying *DWPI* Information.

```
=> d L1 basic
```

TIP

Download your free copy of the *DWPI* Classification Guide from www.scientific.thomson.com/media/scpdf/derwentclass.pdf

```

L1 ANSWER 1 OF 23015 WPINDEX COPYRIGHT 2006 THE THOMSON CORP on STN
AN 1999-538829 [45] WPINDEX
DNN N1999-399158 [45]
TI Controller for hydraulic control system e.g. vehicle traction
control or antilock brake system
DC Q18; X22
IN CARPENTER S E
PA (KELS-C) KELSEY-HAYES CO
PI.B US-----5941612 A 19990824 (199945)* EN 15[5] B60T-8/32
ADT.B US-----5941612 A Provisional US 1996-000017805P 19960517
PRAI 1997US-000856831 19970515
1996US-000017805P 19960517
AB US 5941612 A UPAB: 20060115
NOVELTY - The controller has solenoid (51,52) valves
coupled to a microprocessor (20) that actuate the valves and
which has an arithmetic logic unit that is operable to perform
specific operational functions. A diagnostic subroutine
accessible to the microprocessor is operable to exercise at
least one specific arithmetic logic unit operational function
to verify that the microprocessor can correctly execute the
operational functions.
.....

L1 ANSWER 2 OF 23015 WPINDEX COPYRIGHT 2006 THE THOMSON CORP on STN
AN 1999-538636 [45] WPINDEX
DNN N1999-398970 [45]
TI Slider cleaning method and apparatus for disk drives with
load/unload technology
DC T03
IN GILLIS D R; SUK M
PA (IBMC-C) IBM CORP; (IBMC-C) INT BUSINESS MACHINES CORP
PNC 6
CYC 4
PI SG-----56012 A1 19990118 (199945)* EN 33[8] G11B-5/41
ADT SG-----56012 A1 1997SG-000004207 19971201
PRAI 1997US-000778185 19970102
AB SG 56012 A1 UPAB: 20060115
NOVELTY - An air bearing slider (13) (ABS) is moved across
a stationary cleaning pad (61, 61') formed integrally with the
ramp structure (41) during loading and unloading. Cleaning may
be enhanced by dithering the slider across the stationary pad
e.g. at selected resonant frequencies, to move a larger volume
of debris
.....

```

TIP

The second record has nothing to do with antilock brakes as ABS is also an acronym for air bearing slider. In order to search with greater precision, use the *DWPI* Classification System.

Step 4

Use /DC and the appropriate *DWPI* classification to narrow the search on antilock brakes.

```

=> s L1 and q18/dc
          47067      Q18/DC
L2          4271      L1 AND Q18/DC

```

Step 5

Display the search results using the Display (D) command. See page 14, Displaying DWPI information.

```
=> d L2 ti trial 1-2
```

```
L2 ANSWER 1 OF 4271 WPINDEX COPYRIGHT 2006 THE THOMSON CORP on
STN
TI Brake device for vehicles, has brake pressure reducing unit to
reduce brake pressure of wheel when anti-skid brake system
control is stopped by control prohibition unit, with respect
to condition when control is not stopped
AN 2006-395968 [41] WPINDEX
DNN N2006-331738 [41]
TT TT: BRAKE DEVICE VEHICLE PRESSURE REDUCE UNIT WHEEL ANTI SKID
SYSTEM CONTROL STOP PROHIBIT RESPECT CONDITION
DC Q18; X22
IPCI B60T0008-17 [I,A]; B60T0008-17 [I,C]; B60T0008-1761 [I,A];
B60T0008-88 [I,C]; B60T0008-96 [I,A]
MC EPI: X22-C02C; X22-C02C3

L2 ANSWER 2 OF 4271 WPINDEX COPYRIGHT 2006 THE THOMSON CORP on
STN
TI Fluid filling apparatus for use in anti-lock brake system used
in vehicle e.g. truck, has connection pipes which are
connected to ports
AN 2006-395911 [41] WPINDEX
DNN N2006-331681 [41]
TT TT: FLUID FILL APPARATUS ANTI LOCK BRAKE
SYSTEM VEHICLE TRUCK CONNECT PIPE PORT
DC Q18
IPCI B60T0017-00 [I,A]
```

Derwent classification sample page

Q Mechanical

Mechanical Engineering - all IPC B60-B68, E and F.

Q1 Vehicles in General

- Q11 Wheels, tyres, connections (B60B-D)
- Q12 Suspension systems (B60G)
- Q13 Powertrain, chainset, transmission systems and their control (B60K,W, B62M)
- Q14 Vehicle accessories (B60H,N,Q,R, B62H-J)
- Q15 Vehicle arrangements for transporting special loads (B60P)
- Q16 Vehicle servicing, maintenance, cleaning equipment, vehicle design and manufacture (B60S)
- Q17 Vehicle construction, fittings, propulsion arrangements (B60J-K,R,V-W)
- Q18 Brake systems, steering systems, control (B60T, B62L)
- Q19 Vehicle applications

Q2 Special Vehicles

- Q21 Railways (B60L-M, B61)
- Q22 Hand/animal drawn vehicles (B62B-C)
- Q23 Cycles – discontinued 200607 and incorporated into Q11-Q19
- Q24 Ships, waterborne vessels, related equipment (B63)
- Q25 Aircraft, aviation, cosmonautics (B64)

Q3 Conveying, Packaging, Storing

- Q31 Packaging, labelling (B65B,C)
- Q32 Containers (B65D001-037)
- Q33 Closures (B65D039-055)
- Q34 Packaging elements, types (B65D057-091)
- Q35 Refuse collection, conveyors (B65F,G)
- Q36 Handling thin materials (B65H)
- Q37 Container traffic (pre-1984 only - B65J)
- Q38 Hoisting, lifting, hauling (B66)
- Q39 Liquid, handling, saddlery, upholstery (B67,8)

Q4 Buildings, Construction

- Q41 Road, rail, bridge construction (E01)
- Q42 Hydraulic engineering, sewerage (E02,3)
- Q43 General building constructions (E04B)
- Q44 Structural elements (E04C)
- Q45 Roofing, stairs, floors (E04D,F)
- Q46 Building aids, special structures (E04G,H)
- Q47 Locks, window and door fittings (E05)
- Q48 Blinds, shutters, ladders, doors (E06)
- Q49 Mining (E21)

Q5 Engines, pumps, compressors, fluid pressure actuators

- Q51 Internal combustion engines, reciprocating engines, rotary engines (F01K-P, F02B,D,F, G,M,N,P)
- Q52 Reaction engines, external combustion, gas turbines, rockets (F01D, F02C,K,M)
- Q53 Positive displacement fluid engines (i.e. driven by fluid) (F03C)
- Q54 Non-positive displacement fluid engines (i.e. driven by fluid), Miscellaneous motors and machines for producing mechanical power/thrust (F03B,D,G,H)
- Q55 Positive displacement fluid machines/pumps/compressors (i.e. for driving fluid) (F04B,C)
- Q56 Non-positive displacement fluid machines/pumps/compressors (i.e. for driving fluid) (F04D,F)
- Q57 Fluid-pressure actuators, hydraulic/pneumatics in general (F15)

Q6 Engineering Elements

- Q61 Fastening elements, connections (F16B)
- Q62 Shafts and bearings (F16C)
- Q63 Couplings; clutches, brakes; springs; dampers (F16D,F)
- Q64 Belts, chains, gearing (F16G,H)
- Q65 Pistons, cylinders, packing (F16J)
- Q66 Valves, taps, cocks, vents (F16K)
- Q67 Pipes, joints, fittings (F16L)
- Q68 Other engineering elements (F16M-S)
- Q69 Storing/distributing gas/liquid (F16T, F17)

Q7 Lighting, Heating

- Q71 Lighting (F21)
- Q72 Steam generation (F22)
- Q73 Combustion equipment/processes (F23)
- Q74 Heating, ranges, ventilating (F24)
- Q75 Refrigeration, liquefaction (F25)
- Q76 Drying (F26)
- Q77 Furnaces, kilns, ovens, retorts (F27)
- Q78 Heat exchange in general (F28)
- Q79 Weapons, ammunition, blasting (F41,42)

Using the International Patent Classification System

Find all patents relating to illumination for fountains

The International Patent Classification System (IPC) is a hierarchical classification system produced by the World Intellectual Property Organization (WIPO). This is the patent classification system used by patent offices worldwide. It has been included in *DWPI* records since 1970. The IPC covers all areas of technology and is a useful system that will allow searching with great precision.

The 8th Edition of the IPC, also known as the IPC Reform, was introduced in January 2006. The 8th Edition saw the introduction of continual reclassification of all documents with each future revision of IPC codes. Prior to this revisions of the IPC only became effective from the date of introduction onwards and meant that for a full retrospective search it was necessary to use IPC codes from all previous editions. This does though mean that users need to consider the impact of potentially frequent changes to IPC classifications in their searches.

The 8th Edition of the IPC also saw the introduction of two levels of IPC, the Core and Advanced levels. Advanced IPC codes are generally applied by the larger patent offices and Core IPC codes by the smaller offices. This means that users will need to search both Core and Advanced IPC codes for their area of interest to ensure comprehensive worldwide retrieval. See page 48, Using the International Patent Classification System (Sample Page).

TIP

You can look up IPCs on the WIPO web site at <http://www.wipo.int/classifications/ipc/en/>

Step 1

Enter File WPINDEX to access *Derwent World Patents Index*.

```
=> file wpindex
COPYRIGHT (C) 2006 THE THOMSON CORPORATION
```

Step 2

Conduct a Subject/Keyword search on illumination of fountains. See page 35, Subject/Keyword Searching.

```
=> s fountain? and (light? or illumin?)
          4233      FOUNTAIN?
          963614    LIGHT?
          119694    ILLUMIN?
L1        603      FOUNTAIN? AND (LIGHT? OR ILLUMIN?)
```

Step 3

Display your search results using the Display (D) command. See page 14, Displaying *DWPI* Information.

TIP

The initial Keyword Search has resulted in a mixture of relevant documents and unrelated material because the keywords used can appear in many different contexts. In order to focus on the relevant topic, combine the keywords with the appropriate IPC. See page 48, Using the International Patent Classification System Sample Page.

```
=> d L1 ti trial
```

```
L1 ANSWER 1 OF 603 WPINDEX COPYRIGHT 2006 THE THOMSON CORP on STN
TI Cleaner for cleaning the surface of a body of water, e.g. a
pool
AN 1999-526982 [44] WPINDEX
DNN N1999-390349 [44]
TT TT: CLEAN SURFACE BODY WATER POOL
DC Q46
IC ICM E04H-004/16
PNC 1
CYC 1

L1 ANSWER 2 OF 603 WPINDEX COPYRIGHT 2006 THE THOMSON CORP on STN
TI Spectacles for correcting age related and age non-related
farsightedness
AN 1999-526416 [44] WPINDEX
DNN N1999-389787 [44]
TT TT: SPECTACLE CORRECT AGE RELATED NON
DC P81
IC ICM G02C-001/13
ICS G02C-001/00
PNC 1
CYC 1

L1 ANSWER 3 OF 603 WPINDEX COPYRIGHT 2006 THE THOMSON CORP on STN
TI Molding structure of light storage material writing implement
- is molded with double color material which has light storage
material in entire of shaft, knock and cap.
AN 1999-452449 [38] WPINDEX
DNN N1999-338762
TT TT: STRUCTURE LIGHT STORAGE MATERIAL WRITING IMPLEMENT DOUBLE
MATERIAL LIGHT STORAGE MATERIAL SHAFT KNOCK CAP.
DC P77
IC ICM B43K-029-00
PNC 1
CYC 1

L1 ANSWER 4 OF 603 WPINDEX COPYRIGHT 2006 THE THOMSON CORP on STN
TI Water and light element, with data display, for decoration in
domestic or commercial premises.
AN 1999-420675 [36] WPINDEX
DNN N1999-314200
TT TT: WATER LIGHT ELEMENT DATA DISPLAY DECORATE DOMESTIC
COMMERCIAL PREMISES.
DC P85 Q71 T03 W04
IC ICM F21P-007-00
ICS F21V-033-00; G09F-027-00; G11B-033-04
MC EPI: T03-L; W04-L
PNC 1
CYC 1
```

Step 4

As well as determining IPCs of interest using the WIPO web site, you can also find the appropriate IPC using the Analyze command. STN's Analyze command allows you to conduct a statistical analysis on the answer set of your choice. The results displayed will be in order from most to least posted IPCs in the answer set.

```
=> analyze L1 ipc 1-
L2 ANALYZE L1 1- IPC : 921 TERMS

=> d L2
L2 ANALYZE L1 1- IPC : 921 TERMS
TERM # # OCC # DOC % DOC IPC
-----
1 86 85 14.10 B05B-017-08
2 73 72 11.94 F21P-007-00
3 43 41 6.80 C09D-011-00
4 41 41 6.80 G03F-007-00
5 37 37 6.14 B41C-001-10
6 36 36 5.97 B41M-005-00
7 34 33 5.47 F21V-033-00
8 32 31 5.14 B41J-002-01
9 27 27 4.48 B41N-001-14
10 24 24 3.98 G03F-007-004
```

TIP

Step 4 is based on the assumption that the most heavily posted IPC will be relevant to your search topic. If you have any questions when using IPCs, please contact your local Thomson Scientific Customer Technical Support Center for assistance.

Step 5

Use the Select (SEL) command on L2 requesting that the first term number 1, B05B-017-08, be assigned to an E number to allow you to search this term directly.

```
=> sel L2 1
E1 THROUGH E1 ASSIGNED
```

Step 6

Search the IPC B05B-017-08 in *DWPI* by searching E1.

```
=> s e1
L3 640 B05B-017-08/IPC
(B05B-017-08/IPC)
```

Step 7

Display your search results using the Display (D) command. See page 14, Displaying *DWPI* Information.

```
=> d L3 max 1

L1 ANSWER 1 OF 1 WPINDEX COPYRIGHT 2006 THE THOMSON CORP on STN
AN 1999-445865 [38] WPINDEX
ED 20050522
DNN N1999-332637 [38]
TI Water column for decorative use
DC P27; P42; Q71
PA (LENZ-N) GEBR LENZ GMBH
CYC 1
PI DE----29905989 U1 19990812 (199938)* DE 9[4] A47G-035/00 <-
ADT DE----29905989 U1 1999DE-002005989 19990401
PRAI 1999DE-002005989 19990401
```

TIP

Here is one of the records retrieved using the IPC code B05B-017/08 that was not retrieved using keywords alone. Notice that there is no mention of a fountain; instead the term water column is used. This record and many others like it could have been missed if the IPCs had not been used.

```
IC      ICM A47G-035/00
        ICS B05B-017/08; F21P-007/00
AB      DE 29905989 U1      UPAB: 20050522
        NOVELTY - The column is made of a cylindrical vertical
        container (11) which holds water and has nozzles at its base
        for introducing air, as well as a light source. Decorative
        elements (18) are provided at different heights. The
        decorative elements are semitransparent, and are made from
        sheeting.
        USE - For use in a house as a decorative element.
        ADVANTAGE - The water column provides the viewer with a
        constantly changing visual display.
        DESCRIPTION OF DRAWINGS - The drawing shows a side view of
        the column.
        Vertical container (11)
        Decorative elements (18)
FS      GMPI
```

Suggested methods for finding the right IPCs for your search

- Consult the Official Catchword Index to the IPCs which is available on the WIPO web site at <http://www.wipo.int/classifications/ipc/ipc8/?lang=en>. This is a keyword index of the IPCs.
- Refer to the IPC manual which is available on the WIPO web site at <http://www.wipo.int/classifications/ipc/ipc8/?lang=en>
- Retrieve a few relevant records and examine their IPCs using the TRIAL or TI TRIAL formats.
- Conduct a “rough search” and use the ANALYZE command to determine which IPCs are being used.
- Contact your local Thomson Scientific Technical Support Center for expert assistance.

Format to search IPCs: S ANNA-NNNN/NN/IPC

Remember to search both Core and Advanced IPC codes to ensure comprehensive worldwide retrieval and to consider the impact of potentially frequent changes to IPC classifications following a reclassification cycle.

The screenshot shows the WIPO IPC database interface. The main heading is "B22D CASTING OF METALS; CASTING OF OTHER SUBSTANCES BY THE SAME PROCESSES OR DEVICES". Below this, there are several sub-classes listed with their descriptions and associated symbols. The interface includes a search bar, navigation tabs (Definitions, Illustrations, RCL, Catchwords, Help, Options), and a sidebar with filters for Version, Current symbol, Level, Lang., View mode, Standard seq., and Display.

IPC Definitions Illustrations RCL Catchwords Help Options

B22D **CASTING OF METALS; CASTING OF OTHER SUBSTANCES BY THE SAME PROCESSES OR DEVICES** (shaping of plastics or substances in a plastic state **B29C**; metallurgical processing, selection of substances to be added to metal **C21, C22**)

Note(s)
In this subclass, any **material** to be cast is referred to as metal.

- B22D 1/00** Treatment of fused masses in the ladle or the supply runners before casting (features relating to gas injection, provided on closures of the sliding-gate type **B22D 41/42**, provided on pouring-nozzles **B22D 41/58**)
- B22D 2/00** Arrangement of indicating or measuring devices, e.g. for temperature or viscosity of the fused mass [3]
Casting of pigs, i.e. metal castings suitable for subsequent melting; Similar casting
- B22D 3/00** Pig or like casting (equipment for conveying molten metal **B22D 35/00**)
- B22D 3/02** Moulding of beds
- B22D 5/00** Machines or plants for pig or like casting
 - with rotary casting tables
 - with endless casting conveyers
- B22D 5/04** Casting of ingots, i.e. metal castings suitable for subsequent rolling or forging
- B22D 7/00** Casting ingots (equipment for conveying molten metal **B22D 35/00**)
 - Casting compound ingots of two or more different metals in the molten state, i.e. integrally cast
 - Casting hollow ingots
 - ingot moulds or their manufacture
 - Divided ingot moulds
 - Hot tops therefor
 - Accessories, e.g. for sintering, for preventing splashing
- B22D 9/00** Machines or plants for casting ingots
Particular casting processes; Machines or apparatus therefor
- B22D 11/00** Continuous casting of metals, i.e. casting in indefinite lengths (metal drawing, metal extruding **B21C**)
 - without moulds, e.g. on molten surfaces [2]
 - into open-ended moulds (**B22D 11/06**, **B22D 11/07** take precedence, plants for continuous casting, e.g. for upwardly drawing the strand, **B22D 11/14**) [3]
 - for vertical casting (**B22D 11/043**, **B22D 11/049**-**B22D 11/059** take precedence) [7]
 - Curved moulds (**B22D 11/040**, **B22D 11/050** take precedence) [7]

Subclass level
s **B22D/IPC**

This will retrieve all records listed below this code. Therefore, everything in "Casting of Metals etc." will be grouped together in the answer set.

Group level
s **B22D-5/IPC**

This will gather all records for "Machines or plants for pig or like casting" and any subgroups below it. Do not forget to backfill with zeros for all missing digits where appropriate.

Subgroup level
s **B22D-5/04/IPC**

Using *DWPI* Manual Codes

TIP

Electrical (*EPI*) and Engineering (*EngPI*) Manual Codes are accessible to all searchers of *DWPI*. To search Chemical (*CPI*) Manual Codes you must have a valid subscription with Thomson Scientific. For more information please contact your local Thomson Scientific Support Center.

Search for patent information on video cameras that enable the user to locate their subject automatically by determining the direction of gaze

The *DWPI* Manual Code system is a hierarchical classification system developed to enable precise retrieval of chemical (starting in 1963), electrical (starting in 1980) and engineering (starting 2006; transportation only) patent technology within *DWPI*. This system is the most precise way to search *DWPI* due to the technical skill and consistent indexing provided by Thomson Scientific.

Step 1

Enter File WPINDEX to access *Derwent World Patents Index*.

```
=> file wpindex
COPYRIGHT (C) 2006 THE THOMSON CORPORATION
```

Step 2

Conduct an effective Subject/Keyword Search on video cameras and combine the results with a Subject/Keyword Search on the viewfinder. Combine the result L3 with a Subject/Keyword Search on "direction of gaze" L4.

```
=> s video camera? or camcorder?
      257775 VIDEO
      212189 CAMERA?
      43071 VIDEO CAMERA?
              (VIDEO (W) CAMERA?)
      7679 CAMCORDER?
L1    49948 VIDEO CAMERA? OR CAMCORDER?

=> s focus? or autofocus? or rangefinder? or range finder? or
view finder? or viewfinder?
      905889 FOCUS?
      1167 AUTOFOCUS?
      1001 RANGEFINDER?
      467628 RANGE
      26253 FINDER?
      4382 RANGE FINDER?
              (RANGE (W) FINDER?)
      1775399 VIEW
      26253 FINDER?
      3367 VIEW FINDER?
              (VIEW (W) FINDER?)
      3682 VIEWFINDER?

L2    915871 FOCUS? OR AUTOFOCUS? OR RANGEFINDER? OR
RANGE FINDER? OR VIEWFINDER? OR
VIEWFINDER?
```

```

=> s L1 and L2
L3          9172      L1 AND L2

=> s (eye? or gaze? or sight?) (3a) (line? or direction? or
angle?)
          90675      EYE?
          1261       GAZE?
          18030      SIGHT?
          1227590    LINE?
          1141157    DIRECTION?
          603910     ANGLE?
L4          9091      (EYE? OR GAZE? OR SIGHT?) (3A) (LINE? OR
DIRECTION? OR ANGLE?)

=> s L3 and L4
L5          57        L3 AND L4

```

57 records meet the search criteria

Step 3

Display your search results using the Display (D) command. See page 14, Displaying *DWPI* Information.

```

=> d L5 ti trial 1-2
L5  ANSWER 1 OF 57 WPINDEX COPYRIGHT 2006 THE THOMSON CORP on STN
TI  Capturing image with image sensor package by receiving
    radiation comprising image at angle to line of sight
    of image sensor, and reflecting radiation towards active
    surface of image sensor with first panel.
AN  2004-354518 [33]      WPINDEX
DNN  N2004-283206      DNC C2004-134999
TT  TT: CAPTURE IMAGE IMAGE SENSE PACKAGE RECEIVE RADIATE COMPRISE
    IMAGE ANGLE LINE SIGHT IMAGE SENSE REFLECT RADIATE ACTIVE
    SURFACE IMAGE SENSE FIRST PANEL.
DC  A85 L03 W02 W04
IC  ICM H01L-027-00
MC  CPI:  A12-E11; A12-E13; L04-E05A
    EPI:   W02-F01A; W04-M01C5
PNC  1
CYC  1

L5  ANSWER 2 OF 57 WPINDEX COPYRIGHT 2006 THE THOMSON CORP on STN
TI  Driver gaze direction detection method for airplane,
    determining focus of video camera mounted on
    vehicle with respect to driver's pupil and radius of driver's
    pupil, based on image photographed by camera.
AN  2004-234609 [22]      WPINDEX
DNN  N2004-186104
TT  TT DRIVE GAZE DIRECTION DETECT METHOD AEROPLANE DETERMINE
    FOCUS VIDEO CAMERA MOUNT VEHICLE RESPECT DRIVE PUPIL
    RADIUS DRIVE PUPIL BASED IMAGE PHOTOGRAPH CAMERA.
DC  S02
IC  ICM  G01B-011-26
MC  EPI:  S02-A03B4
PNC  1
CYC  1

```

TIP

This Subject/Keyword Search has retrieved some information that is relevant to the topic. Use *DWPI* Manual Codes to help overcome the difficulty of choosing appropriate keywords.

Step 4

Search on the appropriate *DWPI* Manual Codes. Sub-group W04-M01 covers video cameras and W04-M01D2G is for the determination of eye-gaze direction. Combined with either W04-M01D2C (range finding and subject location/tracking) or W04-M01D5D (automatic focus control), your topic is defined.

Note: W04-M01D2G was only introduced in 1997. To find all earlier records, the *DWPI EPI* Manual Codes User Guide (Part I) indicates that you should combine your search with S05-D01C5A (electrical and electronic measurements of the body for non-medical purposes).

```

=> s w04-m01d2g/mc and (w04-m01d2c or w04-m01d5d)/mc
      W04-M01D2G      EYE-GAZE DIRECTION DETERMINATION
      W04-M01D2C      RANGE FINDING AND SUBJECT LOCATION/
                       TRACKING
      W04-M01D5D      AUTOMATIC FOCUS CONTROL
      143              W04-M01D2G/MC
      2208             W04-M01D2C/MC
      2068             W04-M01D5D/MC
L6      23            W04-M01D2G/MC AND (W04-M01D2C OR W04-
                       M01D5D)/MC

=> s s05-d01c5a/mc and (w04-m01d2c or w04-m01d5d)/mc
      S05-D01C5A      MEASUREMENTS FOR NON-MEDICAL PURPOSES
      W04-M01D2C      RANGE FINDING AND SUBJECT LOCATION/
                       TRACKING
      W04-M01D5D      AUTOMATIC FOCUS CONTROL
      6893            S05-D01C5A/MC
      2208            W04-M01D2C/MC
      2068            W04-M01D5D/MC
L7      168          S05-D01C5A/MC AND (W04-M01D2C OR W04-
                       M01D5D)/MC

=> s L6 or L7
L8      181          L6 OR L7

```

Step 5

Display your search results using the Display (D) command. See page 14, Displaying *DWPI* Information.

```

=> d L8 ti trial 1-2
L8      ANSWER 1 OF 181 WPINDEX COPYRIGHT 2006 THE THOMSON CORP on STN
TI      View finder apparatus with gaze detector for video camera,
      still camera - has finder mode detector that identifies state
      of eye point regulation based on which operation of gaze
      detector is controlled.
AN      1998-023316 [03]      WPINDEX
DNN     N1998-017858
TT      TT: VIEW FINDER APPARATUS GAZE DETECT VIDEO CAMERA STILL
      CAMERA FINDER MODE DETECT IDENTIFY STATE EYE POINT
      REGULATE BASED OPERATE GAZE DETECT CONTROL.
DC      P81 P82 S05 S06 W04
IC      ICM G03B-013-02
      ICS G02B-007-28; G03B-017-00; H04N-005-00; H04N-005-225
MC      EPI: S05-D01C5A; S06-B01E; W04-M01B1; W04-M01D2C;
      W04-M01D2G; W04-M01D3
PNC     2
CYC     1

```

```
L8 ANSWER 1 OF 181 WPINDEX COPYRIGHT 2006 THE THOMSON CORP on STN
TI Remote monitoring appts for surveillance object in dangerous
places e.g. elevations in main body - has video transmission
unit which performs infrared transmission of picked-up video
information to main body which is then displayed.
AN 1997-379449 [35] WPINDEX
DNN N1997-315633
TT TT: REMOTE MONITOR APPARATUS SURVEILLANCE OBJECT DANGER PLACE
ELEVATE MAIN BODY VIDEO TRANSMISSION UNIT PERFORMANCE
INFRARED TRANSMISSION PICK UP VIDEO INFORMATION MAIN BODY
DISPLAY.
DC P81 P82 S02 S05 T01 W02 W04
IC ICM H04N-005-225
ICS G01B-011-00; G02B-007-28; G03B-015-00; G06T-001-00;
G06T-007-60; H04N-005-64
MC EPI: S02-A03B; S05-D01C5A; T01-C10; T01-J10B2; W02-F01;
W04-M01D1A; W04-M01D2C; W04-M01D2G
PNC 1
CYC 1
```

Competitive Intelligence: Early Warning

What patent applications does Microsoft have pending in the US Patent Office?

Step 1

Enter File WPINDEX to access *Derwent World Patents Index*.

```
=> file wpindex
COPYRIGHT (C) 2006 THE THOMSON CORPORATION
```

Step 2

Conduct an effective Assignee search. See page 28, Assignee/Company/Agent Searching

```
=> e microsoft/pa
E1          2      MICROSMART/PA
E2          2      MICROSMART APPLIED MATERIALS CORP/PA
E3         10619   -> MICROSOFT/PA
E4          1      MICROSOFT BUSINESS SOLUTIONS APS/PA
E5          2      MICROSOFT CO/PA
E6         10615   MICROSOFT CORP/PA
E7          2      MICROSOFT CORP INC/PA
E8          1      MICROSOFT INC/PA
E9          35     MICROSOFTWARE/PA

=> s e3-e8
          10619   MICROSOFT/PA
          1      "MICROSOFT BUSINESS SOLUTIONS APS"/PA
          2      "MICROSOFT CO"/PA
          10615   "MICROSOFT CORP"/PA
          2      "MICROSOFT CORP INC"/PA
          1      "MICROSOFT INC"/PA
L1         10619   (MICROSOFT/PA OR "MICROSOFT BUSINESS
SOLUTIONS APS"/PA OR "MICROSOFT CO"/PA OR
"MICROSOFT CORP"/PA OR "MICROSOFT CORP
INC"/PA OR "MICROSOFT INC"/PA)

=> s mict/paco
L2          9770   MICT/PACO
                    (MICT-C/PACO)
```

```

=> e microsoft/ag.t
E1          1      MICROSENSOR/AG.T
E2          1      MICROSENSOR TECHNOLOGY, 866 OAK CHASE
                DRIVE, ORLANDO, FL, US/AG.T
E3          1799   -> MICROSOFT/AG.T
E4          2      MICROSOFT CORP/AG.T
E5          6      MICROSOFT CORP./AG.T
E6          5      MICROSOFT CORP., US/AG.T
E7          29     MICROSOFT CORPORATION/AG.T
E8          1      MICROSOFT CORPORATION AMIN & TUROCY, LLP,
                US/AG.T
E9          77     MICROSOFT CORPORATION C/O WESTMAN,
                CHAMPLIN & KELLY, P.A., SUITE 1400 -
                INTERNATIONAL CENTRE, 900 SECOND AVENUE
                SOUTH, MINNEAPOLIS, MN, US/AG.T
E10         8      MICROSOFT CORPORATION C/O WESTMAN,
                CHAMPLIN & KELLY, P.A., SUITE 1600 -
                INTERNATIONAL CENTRE, 900 SECOND AVENUE
                SOUTH, MINNEAPOLIS, MN, US/AG.T
E11         1      MICROSOFT CORPORATION LEE & HAYES PLLC,
                US/AG.T
E12        121    MICROSOFT CORPORATION, ATTN: PATENT GROUP
                DOCKETING DEPARTMENT, ONE MICROSOFT WAY,
                REDMOND, WA, US/AG.T

=> s e3
L3          1799   MICROSOFT/AG.T

=> s l1 or l2 or l3
L4          10713  L1 OR L2 OR L3

```

Step 3

Search for all of Microsoft's priority US applications.

```

=> s L4 and us/prc
                2263530  US/PRC
L5          10616  L4 AND US/PRC

```

Step 4

Remove all of Microsoft's published US patents. This will leave only Microsoft's US patent publications that are still pending in the US Patent Office but have been published elsewhere in the world.

```

=> s L5 not us/pc
                3869896  US/PC
L6          238      L5 NOT US/PC

```

Step 5

Display your search results using the Display (D) command. See page 14, Displaying *DWPI* Information.

```
=> d L6 brief
L6      ANSWER 3 OF 238 WPINDEX COPYRIGHT 2006 THE THOMSON CORP on STN
AN      2006-405693 [42]      WPINDEX
DNN     N2006-338363 [42]
TI      Computer-readable medium has second web service application
        program interfaces (API) represented having both first common
        namespace prefix and second common namespace prefix that is
        sub-namespace of first common namespace prefix
DC      T01
PA      (MICT-C) MICROSOFT CORP
AB      EP 1667020 A2      UPAB: 20060703
        NOVELTY - Second web service application program
        interfaces (API) are represented having both a first common
        namespace prefix and a second common namespace prefix that is
        a sub-namespace of the first common namespace prefix. The
        second web services APIs enable writing of distributed
        message-passing application and having certain common
        characteristics that are not present in all of first web
        service APIs.
        USE - Computer-readable medium.
        ADVANTAGE - Facilitates use of software platform by
        application programs and computer hardware to create and
        interact in distributed computing activities. Obtains unique
        set of API functions to allow for such increased efficiency
        and/or performance.
        DESCRIPTION OF DRAWINGS - The figure shows the block
        diagram of an application program interface (API) layer.
```

Creating a Current Awareness Profile (SDI)

Create an SDI to follow new developments in nappy (diaper) technology

Step 1

Enter File WPINDEX to access *Derwent World Patents Index*.

```
=> file wpindex
COPYRIGHT (C) 2006 THE THOMSON CORPORATION
```

Step 2

Conduct your search. See pages 35, Subject/Keyword Searching.

```
=> s diaper? or napp?
          13416   DIAPER?
          5348   NAPP?

L1          17998   DIAPER? OR NAPP?
```

Step 3

Enter the term SDI.

```
=> sdi
ENTER QUERY L# FOR SDI REQUEST OR (END):L1
ENTER UPDATE FIELD CODE (UP) OR ?:ed
```

Step 4

Here are some options for the update field:

ED	Will retrieve only new inventions (<i>DWPI Basics</i>).
UPP	Will retrieve new inventions (<i>DWPI Basics</i>) and new equivalents added to <i>DWPI Basics</i> .
UPEQ	Will retrieve new equivalents added to <i>DWPI Basics</i> .
UPOA	Will retrieve all new material added to <i>DWPI</i> .

For other update options: enter HELP UPDATE at the => prompt.

TIP

An SDI is a current awareness service that allows you to create a search strategy in *DWPI* and have records meeting your search criteria sent to you automatically.

Step 5

Enter any name followed by the /S to save it as an SDI name.

```
ENTER SDI REQUEST NAME, (AA001/S), OR END:nappy/s
ENTER COST CENTER (NONE) OR NONE:none
ENTER TITLE (NONE):Nappy Current Awareness
ENTER METHOD OF DELIVERY (OFFLINE), ONLINE, EMAIL, OR FAX:email
ENTER EMAIL ID:an.other@thomson.com
ELIMINATE PREVIOUSLY SEEN ANSWERS WITH EACH SDI RUN? Y/(N):y
ENTER PRINT FORMAT (STD) OR ?:iallg
HIGHLIGHT HIT TERMS? (Y)/N:y
```

TIP

If you select e-mail delivery you will receive a message containing hyperlinks to the results which are valid for 90 days.

Step 6

Continue to answer the questions until STN saves your query as an SDI request.

```
Query L1 /has been saved as SDI request, Nappy/s
```

DWPI Country Coverage and Kind Codes

Recent updates to the *DWPI* Country Coverage and Kind Codes list can be found on the Thomson Scientific website www.scientific.thomson.com or type HELP KIND at the STN => prompt.

Country	Status	Covered in <i>Derwent World Patents Index</i>
ARGENTINA (AR)	A	Examined granted patent (1974-1976 only)
AUSTRALIA (AU)	A	Open for public inspection application without examination
	A1	First publication of an unexamined standard patent application or the divisional standard/petty application of a standard patent/patent application
	A2	Amended first publication
	A4	Publication of granted innovation patent
	A5	Amended pre-grant open for public inspection application innovation patent
	A6	Amended post-grant open for public inspection application innovation patent
	A8	Correction to the bibliographic data of an A level publication
	A9	Correction to the patent specification of an A level publication
	B	Examined and accepted patent (from 199308)
	B1	First publication of the patent application occurring at acceptance of the application
	B2	Second publication of the patent application at acceptance of the application
	B4	Publication of a certified innovation patent
	B8	Correction to the bibliographic data of a B level publication
	B9	Correction to the bibliographic data of a B level publication
AUSTRIA (AT)	A	Open for public inspection application without examination (Aufgebot)
	A1	Publication of application with search report (from 200574)
	A2	Publication of application without search report (from 200574)
	A4	A2 document published on the same date as the B document with no corresponding A3 (from 200574)
	A8	Corrected title page of an A document (from 200574)
	A9	Complete reprint of an A document (from 200574)
	B	Examined granted patent (from 199303) (Patentschrift)
	B1	Patent (from 200574)
	B2	Patent amended after opposition (from 200574)
	B8	Corrected title page of a B document (from 200574)
	B9	Complete reprint of a B document (from 200574)
BELGIUM (BE)	A	Patent of invention (until 1986)
	A0	Application published with or without paying the search fee and which has not been examined (max. 6 or 20 years)
	A3	Initial text with search report
	A4	Changed/corrected text with search report
	A5	Text with amended claims and search report

Country	Status	Covered in <i>Derwent World Patents Index</i>
	A6	Patent of invention which has been neither searched nor examined - text as filed (6-year patent)
	A7	Corrected 6-year patent of invention
	B3, B5	Patent of invention - second publication with search report (max. 20 years)
	T	Transfer to BE national patent from EP application
	T7	European transfer
BRAZIL (BR)	A	Open for public inspection application which has been neither searched nor examined (Pedido de privilegio)
	A3	Pipeline patent application
CANADA (CA)	A	Examined granted patent before 1 st Oct 1989 (old law - <2000000) or open for public inspection application from 1 st Oct 1989 (new law - >2000000)
	B	Reissue of original patent (old law)
	C	Granted patents from 1 st Oct 1989 (old and new law)
	E	Reissue patents granted after 1 st Oct 1989 (old and new law)
CHINA (CN)	A	Patent application published before examination
	C	Examined patent application (from 199518)
CZECH REPUBLIC (CZ)	A3	Patent application published before examination according to Law 527/90 (from 199417)
	B6	Granted patent according to Law 527/90 (from 199417)
CZECHOSLOVAKIA (CS)	A	Patent application
	A1	Patent application
	A2	Patent application published in the course of examination (from 199232).
	B	Examined granted patent (from 199301)
DENMARK (DK)	A	Open for public inspection application which has been (i) neither searched nor examined, or (ii) searched, but not examined (from 1978)
	A	Granted patent based on application which has been searched and examined (until 12 th June 1978)
	B	Granted patent which has been searched and examined (from 199301)
EUROPEAN PATENTS (EP)	A	Open for public inspection application
	A1	Open for public inspection application - includes examiner's search report (from 199220)
	A2	Open for public inspection application - examiner's search report not included (from 199221)
	A3	Examiner's search report only for A2 (from 199221)
	A4	Supplementary Search Report
	A8	Corrected title page of an A document
	A9	Complete reprint of an A document
	B	Examined granted specification (pre-199220)
	B1	Examined granted specification (from 199220)
	B2	Amended specification (from 199220)
	B8	Corrected title page of a B document
	B9	Complete reprint of a B document
FINLAND (FI)	A	Open for public inspection application which has been neither searched nor examined
	B	Examined and searched patent application (from 199302)
	B1	Granted patent (new law) (from 199733)
FRANCE (FR)	A	Granted patent (until 1969)
	A	Open for public inspection application (from 1969)
	A1	Open for public inspection application neither searched nor examined

Country	Status	Covered in <i>Derwent World Patents Index</i>
GERMANY (DD) (former Democratic Republic)	A2	Application for certificate of addition to a patent of invention
	A3	Application for certificate of utility
	E	Certificate of addition to a patent of invention (until 1969)
	M	Special patent for medicament (until 1979)
	M	Certificate of addition to a special patent for medicament (until 1979)
	A	Examined granted patent (Patentschriften) (PS)
	A3	Patent specification which has been searched and examined (economic patent) (Wirtschaftspatent)
	A4	Economic patent (Wirtschaftspatent), (additional patent) according to paragraph 29(1) patent law 50
	A5	Patent specification which has been examined as to formalities but not searched (exclusive patent) (Ausschliessungspatent) (AS)
	A7	Patent specification which has been searched and examined (exclusive patent) (Ausschliessungspatent) (AS)
	A8	Patent specification which has been searched and examined (exclusive patent of addition) (Zusatzpatent)
	A9	Open for public inspection application (not published before May 1, 1992) (DD used by DE- office as a distinguishing feature) (Offenlegungsschrift)
	B	Re-examined after grant
	B1	Patent specification which has been searched and examined (economic patent) (Wirtschaftspatent)
	B3	Patent specification which has been searched and examined (exclusive patent) (Ausschliessungspatent)
	B5	Patent specification following an A7 document after an objection
	C	Examined granted patent
	C2	Economic patent (Wirtschaftspatent), amended according to paragraph 19 patent law 83 or corrected/amended according to paragraph 23 VerfAO 83
	C4	Patent specification which has been searched and examined (exclusive patent) (Ausschliessungspatent)
	C5	Patent specification, 3 rd publication according to patent law 83 extension act
GERMANY (DE)	A	Open for public inspection application before examination (from 1968) (Offenlegungsschrift) (OS)
	A	Examined accepted specification (pre-1974) Auslegeschrift (AS)
	A1	Open for public inspection application before examination (from 199301) (Offenlegungsschrift) (OS)
	A8	Correction of patent application (bibliographic change)
	A9	Correction of patent application (claims, description or drawings)
	B	Examined accepted specification (from 1974-1981) Auslegeschrift (AS)
	B3	Examined patent – first publication (from 200404)
	B4	Examined patent – second publication (from 200404)
	B8	Correction of examined patent (bibliographic change)
	B9	Correction of examined patent (claims, description or drawings)
	C	Granted patent from 1981 (from 198138) Patentschrift (PS)
	C1	Examined patent - first publication (from 199252) Patentschrift (PS)
	C2	Examined patent - second publication (from 199252)
	C5	Modified granted patent (previously kind code C3)
	C8	Correction of modified patent (bibliographic change)
C9	Correction of modified patent (claims, description or drawings)	

Country	Status	Covered in <i>Derwent World Patents Index</i>
	E	Granted EP in English or French with DE assigned serial number
	G	Granted EP in German with DE assigned serial number
	T	PCT transfer to DE
	T0	PCT transfer to DE published in non-German language
	T2	Translation of granted EP in English or French with DE assigned serial number
	T5	Translation of PCT international announcement
	T8	Correction of EP application (bibliographic change)
	T9	Correction of EP application (claims, description or drawings)
	U1	Utility Model (199626)
	U8	Correction of Utility Model (bibliographic change)
	U9	Correction of Utility Model (claims, description or drawings)
HUNGARY (HU)	A	Open for public inspection application
	A1	Patent application with search report
	A2	Examined patent application
	B	Granted patent with search report (from 199302)
	B1	Granted patent
	H	Open for public inspection application (from 199223)
	T	English language abstracts of Hungarian patent specifications (from 199223)
INDIA	B	Pre opposition granted applications
	I1	Pre grant (18 months) application - Delhi
	I1	Pre grant (18 months) application - Kolkata
	I3	Pre grant (18 months) application - Mumbai
	I4	Pre grant (18 months) application - Chennai
	P1	PCT application - national phase - Delhi
	P2	PCT application - national phase - Kolkata
	P3	PCT application - national phase - Mumbai
	P4	PCT application - national phase - Delhi
INTERNATIONAL TECHNOLOGY DISCLOSURES (TP)	A	Scientific literature disclosure (ceased publishing June 1994)
IRELAND (IE)	A	Patent Specification (1963-1969 only)
	B	Granted patent (from 199517)
	B3	Short patent (from 199517)
ISRAEL (IL)	A	Application of patent for invention
ITALY (IT)	A	Patent
	B	Unexamined granted patent
JAPAN (JP)	A	Open for public inspection application published before examination (Kokai)
	B	Application published after examination (Kokoku)
	B1	Registered (granted) patent not previously published at the Kokai stage (Tokkyo Koho)
	B2	Registered (granted) patent previously published at the Kokai stage (Toroku)
	W	PCT transfer originating from abroad
	X	PCT transfer originating from Japan
	Y	PCT transfer originating from abroad to Utility Model
	Z	PCT transfer originating from Japan to Utility Model
KOREA SOUTH (KR)	A	Application published before examination
	B	Examined patent application
	B1	Examination patent application (from 199252)
	B2	Examined patent application (1 st publication)
LUXEMBOURG (LU)	A	Patent granted without examination
MEXICO (MX)	A	Patent of Invention (from 199816)

Country	Status	Covered in <i>Derwent World Patents Index</i>
	A1	Published patent application
	A2	Anticipated publication of a patent application
	A4	Regional filing - Jalisco
	A5	Regional filing - Nuevo Leon
	A6	Regional filing - Yucatan
	A7	Regional filing - Guanajuato
	B	Granted patent (patent law 1991) from 199816
NETHERLANDS (NL)	A	Open for public inspection application which has neither been searched nor examined
	B	Examined accepted specification - application which has been searched and examined
	C2	20-year new law granted patent (from 199608)
	C6	Six-year new law petty patent (from 199608)
NEW ZEALAND (NZ)	A	Application which has been searched and examined (from 199301)
NORWAY (NO)	A	Open for public inspection application which has been neither searched nor examined
	B	Examined accepted specification - application which has been searched and examined (from 199301)
	B1	Granted patent (new law)
PCT (WO)	A	Open for public inspection application
	A1	Open for public inspection application with international search report (from 199220)
	A2	Open for public inspection application without international search report (from 199220)
	A3	Open for public inspection application search report for A2 (from 199220)
PHILIPPINES (PH)	A	Patent application (from 199511)
	B1	Granted patent (from 200267)
PORTUGAL (PT)	A	Application for patent of invention
RESEARCH DISCLOSURE (RD)	A	Scientific literature disclosure © Kenneth Mason Publications Limited [2006] www.researchdisclosure.com
ROMANIA (RO)	A	Examined accepted specification
	B	Granted patent according to 1991 law
	B1	Granted patent according to 1991 law
RUSSIAN FEDERATION (RU) (See also Soviet Union)	C	Granted patent of invention
	C1	Granted patent of invention
SINGAPORE (SG)	A	Registrations (from 199513)
	A1	Patent applications (from 199631)
SLOVAKIA (SK)	A3	Patent application according to Law 527/90
	B6	Granted application according to Law 527/90
SOUTH AFRICA (ZA)	A	Patent specification accepted without examination
	AA	Second application with same number
	AZ	Second application with same number
SOVIET UNION (SU)	A	Examined granted patent
	A1	Inventor's certificate
	A2	Addition to inventor's certificate
	A3	Patent
	A4	Patent of addition
	B	Reissued patent

Country	Status	Covered in <i>Derwent World Patents Index</i>
SPAIN (ES)	A	Patent granted without examination (pre-1987)
	A	Patent application published with search report
	A1	Patent application published with search report
	A2	Patent published without search report
	A6	Patent published without search report
	B	Patent published with search report
	B1	Patent published with search report
	T1	Translation of the claims with drawings of EP application
	T3	Translation of granted EP patent
	T4	Corrected translation of a granted European patent
	T5	Modified translation of a granted European patent
SWEDEN (SE)	A	Open for public inspection application which has been neither searched or examined
	B	Examined accepted specification - application has been searched and examined (from 198701)
	C2	Granted patent (new law)
SWITZERLAND (CH)	A	Granted unexamined patent or searched and examined application
	A3	Open for public inspection application which has been searched and preliminarily examined (from 1978)
	A5	Granted unexamined patent
	A8	Correction to the bibliographic data of an A level publication
	A9	Correction to the patent specification of an A level publication
	B	Examined accepted specification
	B5	Granted with examination
TAIWAN (TW)	A	Examined patent application - old law
	B1	Examined patent application - new law
UNITED KINGDOM (GB)	A	Examined granted specification (<2000000)
	A	Open for public inspection application which has been searched but not examined (2000000+)
	B	Granted patent which has been searched and examined specification (from 198206)
UNITED STATES (US)	A	Examined granted patent (until December 2000)
	A1	Open for public inspection application (from 2 nd January 2001)
	A2	Subsequent/2 nd publication of a patent application (from 2 nd January 2001)
	A9	Corrected published utility patent application
	B	Re-examination certificate (prior to 2 nd January 2001)
	B1	Re-examination certificate (prior to 2 nd January 2001)
	B1	Utility patent grant with no pre-grant publication (from 2 nd January 2001)
	B2	Re-examination certificate (prior to 2 nd January 2001)
	B2	Utility patent grant with pre-grant publication (from 2 nd January 2001)
	B3	Re-examination certificate (prior to 2 nd January 2001)
	C1	First re-examination certificate (from 2 nd January 2001)
	C2	Second re-examination certificate (from 2 nd January 2001)
	E	Reissue patent
	H	Defensive specification
	H	Statutory invention registration (replaces defensive publication)
N	NTIS-published invention application	

DWPI Country Coverage

Date of Inclusion

Country	Year	DWPI Update
Argentina (AR)	1974-1976 only	
Australia (AU)	1983 (also 1963-1969)	198310
Austria (AT)	1975	197515
Belgium (BE)	1963	
Brazil (BR)	1976	197601
Canada (CA)	1963	
China (CN)	1987	198701
Czech Republic (CZ)	1993	199319
Czechoslovakia (CS)	1975-1994	197520
Denmark (DK)	1974	197445
European Patents (EP)	1978	197849
Finland (FI)	1974	197445
France (FR)	1963	
Germany (East) (DD)	1963	
Germany (DE)	1963	
Hungary (HU)	1975	197526
India	2005	
International Technology Disclosures (TP)	1984-1993	198408
Ireland (IE)	1963-1969; 1995	199517
Israel (IL)	1975	197515
Italy (IT) (Subjects from Section A only)	1966-1969	
	1978	197801
Japan (JP)	1963	
Korea (KR) (South)	1986	198640
Luxembourg (LU)	1984	198443
Mexico (MX)	1998	199816
Netherlands (NL)	1963	
New Zealand (NZ)	1993	199301
Norway (NO)	1974	197448
Patent Cooperation Treaty (WO)	1978	197849
Philippines (PH)	1995	199511

Country	Year	DWPI Update
Portugal (PT)	1974	197452
Research Disclosure (RD)	1978	197809
© Kenneth Mason Publications Limited [2006] www.researchdisclosure.com		
Romania (RO)	1975	197532
Russian Federation (RU)	1994 (Russia)	199406
Singapore (SG)	1995	199513
Slovakia (SK)	1994	199417
South Africa (ZA)	1963	
Soviet Union (SU)	1963-1994	
Spain (ES)	1983	198334
Sweden (SE)	1974	197442
Switzerland (CH)	1963	
Taiwan (TW)	1993	199324
United Kingdom (GB)	1963	
United States (US)	1963	

Thomson Scientific Standard Abbreviations

Thomson Scientific has abbreviated many commonly occurring words in titles and abstracts (Basic Index) over time. Since 1998 it has been policy not to abbreviate where possible and thus, for comprehensive results, the abbreviation should be searched together with the corresponding full term.

Abbreviation		Abbreviation	
addition(s)	addn./addns.	melting point	m.pt.
administration	admin.	minimum	min.
amount(s)	amt./amts.	mixture(s)	mixt./mixts.
apparatus	appts.	molecule(s)	mol./mols.
aqueous	aq.	obtained	obtd.
atmosphere	atmos.	optionally	opt.
boiling point	b.pt.	oxidation	oxidn.
coefficient(s)	coefft./coeffts.	particularly	partic.
composition(s)	compsn./compsns.	parts by weight	pts. wt.
compound(s)	cpd./cpds.	parts per million	ppm.
concentrated	conc.	precipitate(s)	ppte./pptes.
concentration(s)	concn./concns.	precipitated	pptd.
condensation	condensn.	precipitation	pptn.
containing	contg.	preferably	pref.
continuation	cont.	preparation	prepn.
continuation in part	c.i.p.	prepared	prepd.
corresponding	corresp.	primary	prim.
derivative(s)	deriv./derivs.	product(s)	prod./prods.
determination	determn.	production	prodn.
diameter	dia.	purification	purificn.
dilute	dil.	quaternary	quat.
distillation	distn.	reduction	redn.
divided/division	div.	saturated	satd.
divided out of	div. ex	secondary	sec.
equivalent(s)	equiv./equivs.	separated	sepd.
especially	esp.	separating	sepg.
evaporation	evapn.	separation	sepn.
extraction	extrn.	solution(s)	soln./solns.
for example	e.g.	substituent(s)	substit./substits.
gram molecule(s)	mole./moles.	substituted	substd.
group(s)	gp./gps.	temperature(s)	temp./temps.
insoluble	insol.	tertiary	tert.
liquid	liq.	that is	i.e.

Abbreviation		Abbreviation	
manufacture	mfr.	volume	vol.
manufactured	mfd.	weight	wt.
manufacturing	mfg.	with respect to	w.r.t.
maximum	max.		

Other standard abbreviations for units of measurement, electrical and engineering elements, chemical groups and chemical formulae are also used in abstracts, e.g.:

- Standard abbreviations for units and quantities, e.g. mm, g, and pH, pKa, N for normality
- Well-known standard abbreviations for compounds, e.g. PVC and PTFE
- Standard abbreviations for electrical and general engineering elements and terms, e.g. FET, MOSFET, TTL, FM, AFC, TDC
- Standard abbreviations for chemical groups, e.g. Me, Et, Ph.
- Chemical formulae and standard symbols for elements, e.g. H₂SO₄, Cu, Zn
- The abbreviations wt% and vol% for percentage by weight and percentage by volume, respectively

Glossary of Patent Terms

Application (for Patent)

Papers comprising petition, specification, drawings (when required), one or more claims, oath or declaration, and filing fee, whereby an applicant seeks a patent.

Assignee

The person(s) or corporate body to whom all or limited rights under a patent are legally transferred.

Basic Patent

The first member of a *DWPI* patent family. This is the first published patent received by Thomson Scientific and processed.

Claim(s)

The definition of the monopoly rights that the applicant is trying to obtain for the invention. The claims become the actual monopoly that is given when/if the patent is granted.

Continuation

Applicable mainly in the US, continuations are second or subsequent applications which are filed while the original parent application is pending. Continuations must claim the same invention as the original application to gain the benefit of the parent filing date.

Continuations-in-part

Generally referred to as a 'c.i.p.', this is essentially the same as the continuation with the exception that some new material may be included. The c.i.p. must be filed while the original parent application is pending for any disclosed material in common with the parent.

Defensive Publication

A publication and disclosure to the public of a pending patent application.

Division

If the patent office decides that an application covers too large an area to be considered as a single patent, then the application is split into one or more divisional applications.

Equivalent

Specifications published by different patent offices all relating to the same invention and all sharing the same priority application (See Non-Convention Equivalents).

European Patent Convention (EPC)

Thirty one European countries are parties to the European Patent Convention. A patent application filed under this convention will, when granted, usually automatically be effective in each of the countries designated by the applicant.

Filing Date

The date when the application reaches the patent office in complete form.

First to File

The applicant who is the first to file an application for an invention will be awarded the patent over all others. This is the present law in all countries other than the US.

First to Invent

In the US, the applicant who is the first to invent will be awarded the patent over all others.

Non-Convention Equivalents

An application filed in a second or subsequent country which does not claim a priority application in another country. Usually a result of filing the application after the 12-month Convention period, but may be within that period by choice of the applicant.

Novelty

The concept that the claims must be totally new. The invention must never have been made public in any way, anywhere, before the date on which the application for a patent is filed. In the US, this is determined by the date of invention.

Obviousness

The concept that the claims defining an invention in a patent application must involve an inventive step if, when compared with what is already known (i.e. prior art), it would not be obvious to someone skilled in the art.

Paris Convention

Having filed a first patent application (usually in his/her own country), the applicant is allowed one year from that date in which to make further applications in member countries and claim the original priority date.

Patent

A document defining the rights conferred by the grant, but often used generally to mean any published specification.

Patent Cooperation Treaty (PCT)

There are currently 132 contracting states to this treaty (as of August 2006). The PCT system offers an advantageous route for international patent protection with reduced costs.

Patent Family

All the equivalent patent publications corresponding to a single invention, covering different geographical regions.

Prior Art

Previously used or published technology that may be referred to in a patent application or examination report.

Priority Date

The initial date of filing of a patent application, normally in the applicant's domestic patent office. This date is used to help determine the novelty of an invention.

Publication

Documents, including patents of most countries that are printed (published) and are actually or presumptively available to the public.

Search Report

A list of published items (both patent and non-patent literature), issued by the patent examiners checking the novelty of the patent application, which are relevant to the subject of the invention.

Specification

The description, drawings and claims of an invention prepared to support a patent application. The term does not imply that the invention is necessarily new or was ever protected.

World Intellectual Property Office (WIPO)

The organization that administers the Patent Cooperation Treaty (PCT). (See Patent Cooperation Treaty)

Further Information

Customer Technical Support

Expert advice and support is available via our Customer Technical Support staff, to provide a fast and efficient response to all your enquiries. The experienced Technical Support staff has an in-depth knowledge of the products and services offered by Thomson Scientific and are familiar with the command languages of the various online hosts.

From general customer queries through to complex technical questions, the Technical Support department is there to help you.

Contact Details

Email (all regions)

Please use the Feedback Form on the following Web page:
www.scientific.thomson.com/support/techsupport

Your message will automatically be directed to your nearest Support Center.

Europe, Middle East and Africa

Thomson Scientific
14 Great Queen Street
London WC2B 5DF
United Kingdom

Phone: +44 (0)20 7344 2999
Fax: +44 (0)20 7344 2900

Americas

Thomson Scientific
3501 Market Street
Philadelphia, PA 19104
USA

Phone: +1 800 336 4474 ext. 1591
+1 215 386 0100
Fax: +1 215 386 6362

Japan

Thomson Corporation K.K.
Palaceside Building, 5F East
1-1-1 Hitotsubashi
Chiyoda-ku
Tokyo 100-0003

Phone: 0800 888 8855 (from Japan
only)
+81 3 5218 6500
Fax: +81 3 5218 6536

Asia Pacific (Singapore)

Thomson Scientific
16 Collyer Quay
22nd Floor
Hitachi Tower
Singapore 049318

Phone: +65 6879 4118
Fax: +65 6223 2634

China

Thomson Scientific
Room 407,
Raycom InfoTech Park Tower A
No. 2 Kexueyuan South Road
Haidian District
Beijing 100080
P.R.China

Phone: +86 10 8286 2099
Fax: +86 10 8286 2088

Korea

Thomson Scientific
13F Hungkuk Life Insurance Bldg.
226 Shinmunro 1-ga, Jongro-gu
Seoul 110-786
Korea

Phone: 080 010 8100
+82 2 2076 8100
Fax: +82 2 2076 8122

Australia and New Zealand

Thomson Scientific
Level 5
1000 Harris Street
Pymont, NSW 2009
Australia

Phone: Australia 1800 007 214
New Zealand 0800 443 162
Fax: +65 6223 2634

Thomson Scientific Website

The Thomson Scientific website (www.scientific.thomson.com) provides comprehensive reference material for patent information searchers, and is updated daily with product and patent news. The website includes searchable databases for the Patentee and Manual codes, and hundreds of downloadable product samples and user guides. You can also reserve your place on our product training classes, check dispatch details for our printed and CD-ROM products, and monitor country coverage and latest update information for the *Derwent World Patents Index*. Visitors can also sign up to receive a monthly email which highlights new additions to the website.

Customer Support Center

Optimize your use of Thomson Scientific products and services. In our comprehensive Support Center you are just a click away from the reference materials you need.
www.scientific.thomson.com/support

Customer Training

Thomson Scientific provides a selection of face-to-face and web-based training for both novice and advanced users of our databases. Our expert trainers can help you get more from your information resources.

Patent Copy Service

Having completed your search you can order quality copies of patent documents issued around the globe. As holders of the world's largest private collection of international patents, Thomson Scientific provides a fast and efficient service. In addition, through a global network of contacts, Thomson Scientific regularly locates and supplies old and unusual patents.

The complete file history of a patent can also be supplied. This detailed document enables you to track the entire life of a patent from application through amendments to grant (if this occurred). All this information is presented neatly tabbed and bound.

To make use of these services, simply contact your local Thomson Scientific Support Center.

User Guides

To help you search *Derwent World Patents Index* more effectively, Thomson Scientific provides a comprehensive range of user guides, all written by specialists in their field. The user guides listed below include topics relevant to searching the database. The majority of these are available as PDF files on our web site at www.scientific.thomson.com/support/userguides/

User Guide

Global Patent Sources

Guide to Patent Expiries

Tools of the Trade on STN

Title Terms

Derwent Classification

Patentee Codes

CPI Manual Codes

EPI Manual Codes

CPI Chemical Indexing User Guide

CPI Chemical Indexing Guidelines

Chemistry Resource on STN

CPI Plasdac Coding Systems

Polymer Indexing Dictionary

Polymer Indexing Reference Manual

Polymer Indexing System Description

Polymer Indexing Thesaurus

Polymer Indexing Hierarchy

Online Sources

STN provides two sources of online help for *Derwent World Patents Index*:

Help	Description
Summary Sheets	Available on the web at www.stn-international.de
Online Help	Accessed online by typing HELP at the => prompt

Electronic Resources

- www.scientific.thomson.com Thomson Scientific website
- www.stn-international.de STN (Europe)
- www.cas.org/stn.html STN (North America)
- www.jst.go.jp/en STN (Japan)
- www.jaici.or.jp STN (Japan)
- www.uspto.gov US Patent Office Web site
- www.european-patent-office.org European Patent Office Web site
- www.jpo.go.jp Japanese Patent Office Web site
- www.wipo.org World Intellectual Property Office Web site
- www.wipo.int/classifications/ipc/en International Patent classification (IPC)

Did you know that you can now access *DWPI* via web interfaces?

DWPI on STN can be searched on the following web interfaces:

STN on the Web www.stnweb.fiz-karlsruhe.de
 www.stnweb.cas.org

STN Easy www.stneasy.fiz-karlsruhe.de
 www.stneasy.cas.org

Other Thomson Scientific databases available on STN

The following Thomson Scientific databases are available for searching on STN:

- BIOSIS Previews®
- *Chemistry Resource*
- Crop Protection File (Static file)
- Derwent Biotechnology ResourceSM
- *Derwent Drug File*
- *Journal of Synthetic Methods*
- *Derwent World Patents Index First View*SM
- *GENESEQ*TM (DGENE)
- International Pharmaceutical Abstracts (IPA)
- *LitAlert*[®]
- *Patents Citation Index*TM
- *Science Citation Index*[®] (SciSearch)
- Veterinary Drug File (Static file)

For more information on these Thomson Scientific databases, please visit www.scientific.thomson.com.