

# STN<sup>®</sup>

## Introduction to Derwent World Patents Index<sup>®</sup> (DWPI<sup>SM</sup>)

Robert Austin – FIZ Karlsruhe

# Agenda

- What is the Derwent Word Patents Index (DWPI) and why should I use it ?
  - the value of value-add
- A tour through a typical database record
  - Invention and member levels
- Keyword/text searching
- Assignees & Inventors
- Patent/application numbers
  - Dates & authorities

# What is Derwent World Patents Index?

- The largest value-added patent database
  - Covers 47 patenting organizations
- An index of global patent publications
  - Concise patent families
  - Enhanced English titles and abstracts
  - Patent Assignee Codes
  - Classification and Indexing
- Produced by Thomson Reuters

# Why should I use DWPI?

- Patent information users greatly benefit from intellectually analyzed patent database content
  - Enables efficient retrieval with highly relevant results
  - Assists in obtaining a comprehensive search result
- For patent searches of significant commercial importance, it is essential to search value-added patent databases and first-level patent data
  - STN has a complete offering on a single, professional search platform

# What is first-level patent data?

- Information derived only from the original publication of the document
  - Full-text databases direct from patent offices (e.g. EPFULL), or generated by Optical Character Recognition (OCR) techniques (e.g. PCTFULL)
  - Bibliographic databases from national offices (e.g. KOREAPAT)
  - Bibliographic databases with international coverage (e.g. INPAFAMDB/INPADOCDB)

# What is “value-add” in DWPI?

- An enhanced, meaningful title (TI), and patent-focused abstract (AB) reveal the actual invention
- An additional Technology Focus (TECH) abstract, highlights the preferred features of the invention
- A high-quality bibliography summarizes global publication details for a particular invention
- Patent Assignee Codes (PACO) assist in retrieving comprehensive company search answer sets
- Proprietary subject indexing and classification, combined with original Patent Office classification, provide precise and unique search options

# Example: The value of enhanced titles

(12) **United States Patent**  
**Mannak**

(10) **Patent No.:** **US 6,169,908 B1**  
(45) **Date of Patent:** **Jan. 2, 2001**

(54) **TELECOMMUNICATION SYSTEM**

FOREIGN PATENT DOCUMENTS

(75) Inventor: **Jacobine Johannette Mannak**, The Hague (NL)

0 319 210 6/1989 (EP) .  
0 514 360 A2 \* 4/1992 (EP) ..... H04Q 7/04  
0 503 813 9/1992 (EP) .

AN 1998-534291 [46] WPINDEX

TI Telecommunications system for combined pager and cellular telephone terminal - includes terminals with pager section that can be detached, transmits to pager section calls from callers who form part of user preferred group.

(22) Filed: **Mar. 20, 1998**

(74) *Attorney, Agent, or Firm*—Michaelson & Wallace; Peter L. Michaelson

(30) **Foreign Application Priority Data**

(57) **ABSTRACT**

Mar. 21, 1997 (NL) ..... 1005601

(51) **Int. Cl.**<sup>7</sup> ..... **H04B 1/16**; H04B 1/38;  
H04Q 7/20; H04Q 5/22; H04M 1/00

(52) **U.S. Cl.** ..... **455/557**; 455/557; 455/575;  
455/343; 455/426; 340/825 44

A telecommunication system comprising a telecommunication network apparatus and at least one terminal. The terminal comprises a radiotelephone section and a pager section. The radiotelephone section and the pager section can be uncoupled from and coupled to each other. The

# Example: Find English-language equivalents



19 BUNDESREPUBLIK  
DEUTSCHLAND



DEUTSCHES  
PATENT- UND

12 **Offenlegungsschrift**  
10 **DE 199 47 832 A 1**

5 Int. Cl.<sup>7</sup>:  
**C 08 L 71/12**  
C 08 L 83/04

21 Aktenzeichen: 199 47 832.5  
22 Anmeldetag: 5. 10. 1999  
43 Offenlegungstag: 13. 4. 2000

947 832 A 1

AN 2000-319510 [28] WPINDEX  
TI A fire resistant polyphenylene resin composition useful in the preparation of shaped parts and fire resistant electrical and electronics parts contains an organopolysiloxane having alkyl and aryl residues  
DC A25; A26; V02; V03; V04; W02; W06; X12; X16  
IN MORITOMI S  
PA (SUMO-C) SUMITOMO CHEM CO LTD  
PIA DE 19947832 A1 20000413 (200028)\* DE 11[0] <--  
JP 2000178436 A 20000627 (200036) JA 7  
**US 6258881 B1 20010710 (200141) EN**  
ADT DE 19947832 A1 DE 1999-19947832 19991005; JP 2000178436 A JP 1999-204685 19990719; US 6258881 B1 US 1999-413189 19991005  
PRAI JP 1998-285194 19981007

# How to access DWPI on STN?



Desk-top software providing classic online access, with Web links and search assistants. Includes efficient post-processing and analysis tools for **reports, charts & tables**



<http://stneasy.fiz-karlsruhe.de>

Easy-to-use web access for occasional, basic searches



<http://stnweb.fiz-karlsruhe.de>

Browser based online access for professional searchers with the benefits of the Web

# How to access DWPI on STN? (cont.)

- **FILE WPINDEX**
  - Open access database
- **FILE WPIDS**
  - Subscriber database
- **FILE WPIX**
  - Subscriber database with Extension Abstracts
- **FILE LWPI**
  - The DWPI learning file

# DWPI subject coverage

- 1963      Pharmaceuticals
- 1965      Agriculture Chemicals
- 1966      Plastics & Polymers
- 1970      Rest of Chemistry
- 1974      All technologies

# Agenda

- What is the Derwent Word Patents Index (DWPI) and why should I use it ?
  - the value of value-add
- **A tour through a typical database record**
  - Invention and member levels
- Keyword/text searching
- Assignees & Inventors
- Patent/application numbers
  - Dates & authorities

# DWPI records have two levels

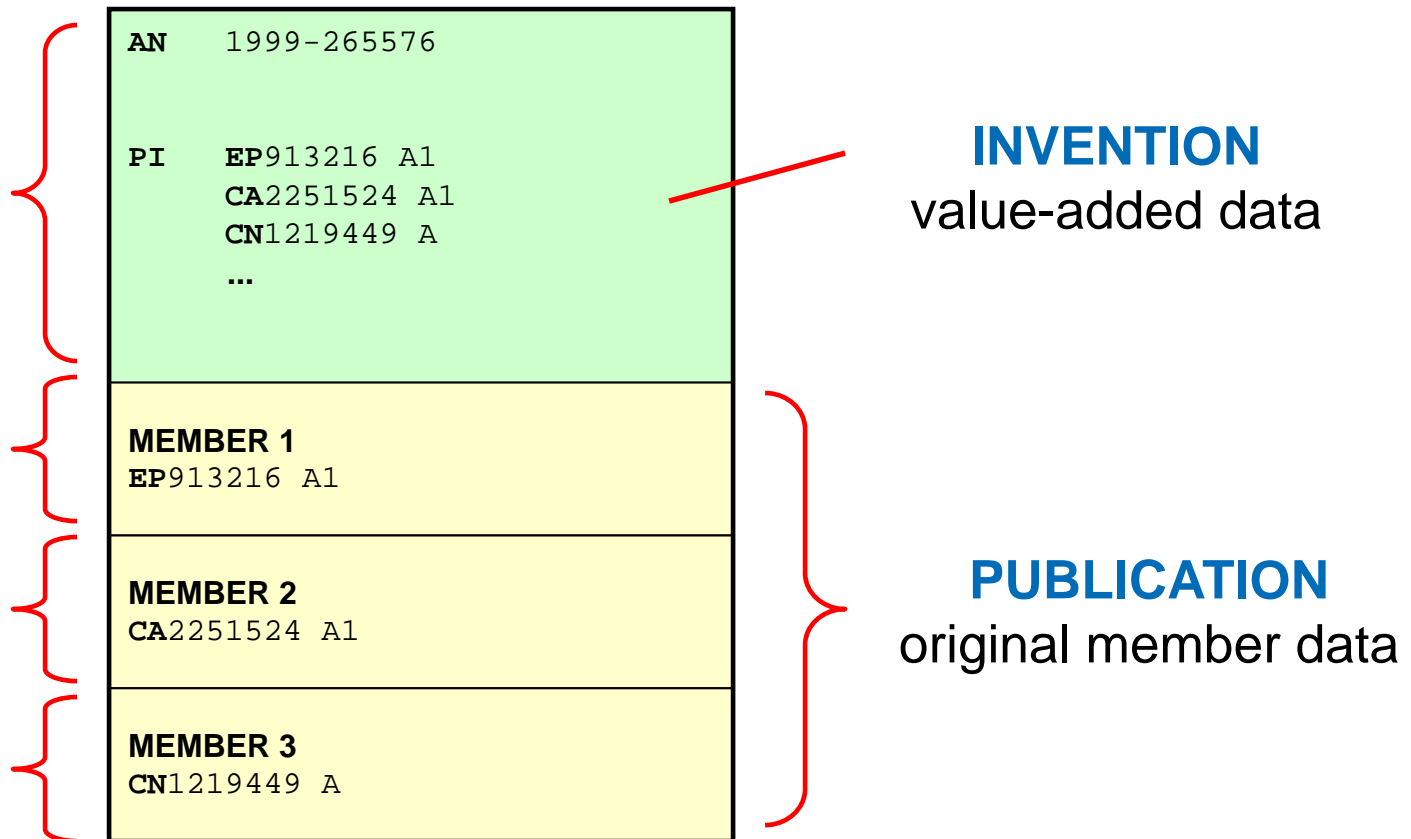

# DWPI invention level data

- Patent family data
- Thomson Reuters value added data
  - Enhanced title and abstract(s)
  - Proprietary classification and indexing
- Deduplicated inventor and assignee data
- Deduplicated patent classifications

# DWPI member level data

- Original titles, abstracts and claim(s)
- Full inventor names and addresses
- Original assignee names and addresses
- Attorney/agent names and addresses
- Available for many DWPI patent authorities
  - WO, EP, AU, DE, JP, GB, US, RU, FR, CA, BR, CH, ES, IN, CN, TW, KR, PH, VN, TH, GC, HK, PL

**Note:** Different patent authorities and publication types have different amounts of data at the member level. See this table for all the details:

[http://www.stn-international.com/fileadmin/be\\_user/STN/pdf/search\\_materials/patents/Tabelle\\_DWPI.pdf](http://www.stn-international.com/fileadmin/be_user/STN/pdf/search_materials/patents/Tabelle_DWPI.pdf)

# A tour through a typical DWPI record

- Enhanced title
- Patent family
- Inventor and assignee
- Enhanced abstract
- Selected drawing image
- Patent classifications
- Original title and abstract
- Claim(s) text

AN 2001-476126 [51] WPINDEX  
 TI Iron, for ironing clothes, has water reservoir, textile additive reservoir and piston and valve pump which mixes water and additive in mixing chamber before discharge at front of iron through pulverizer  
 DC X27  
 IN BOULEAU J; BOULEAU J P  
 PA (BOUL-I) BOULEAU J; (MOUX-C) MOULINEX SA; (SEBS-C) SEB SA  
 PI WO 2001053595 A1 20010726 (200151)\* FR 28[9]  
 FR 2804137 A1 20010727 (200151) FR  
 EP 1248876 A1 20021016 (200276) FR  
 US 20030056406 A1 20030327 (200325) EN  
 TW 499525 A 20020821 (200333) ZH  
 US 6671985 B2 20040106 (200411) EN  
 EP 1248876 B1 20040915 (200460) FR  
 ES 2225476 T3 20050316 (200525) ES  
 RU 2256733 C2 20050720 (200548) RU  
 MX 2002006036 A1 20040901 (200553) ES  
 MX 232066 B 20051110 (200634) ES  
 ADT WO 2001053595 A1 WO 2001-FR112 20010115; FR 2804137 A1 FR 2000-874 20000120; EP 1248876 A1 EP 2001-903945 20010115; EP 1248876 B1 EP 2001-903945 20010115; ES 2225476 T3 EP 2001-903945 20010115; EP 1248876 A1 WO 2001-FR112 20010115; US 20030056406 A1 WO 2001-FR112 20010115; US 6671985 B2 WO 2001-FR112 20010115; . . .  
 FDT ES 2225476 T3 Based on EP 1248876 A; EP 1248876 A1 Based on WO 2001053595 A; US 6671985 B2 Based on WO 2001053595 A; EP 1248876 B1 Based on WO 2001053595 A; RU 2256733 C2 Based on WO 2001053595 A; MX 2002006036 A1 Based on WO 2001053595 A; MX  
 PRAI FR 2000-874 20000120

DWPI enhanced title.

Inventor (IN) and assignee (PA).

DWPI patent family.

Priority Application Information (PRAI).

IC ICM D06F0075-14  
IPCR D06F0075-08 [I,C]; D06F0075-14 [I,A]; D06F0075-22 [I,  
EPC D06F0075-14; D06F0075-22  
NCL NCLM 038/077.500  
AB WO 2001053595 A1 UPAB: 20060117

U.S., European and International Patent classifications.

NOVELTY - Iron (1) has soleplate (2), body (3) and handle (4). Within body are water reservoir (5), textile additive reservoir (12), pump (15) and sprayer/pulverizer (16). Pump, which has two plane disks, two perforated disks and two mobile seals, draws water and additive from respective reservoirs and mixes them in mixing chamber (20) for discharge through pulverizing sprayer (16).

The DWPI enhanced abstract provides a concise summary of the claimed invention.

USE - For ironing clothes.

ADVANTAGE - The arrangement of reservoirs can be more easily installed into the body of the iron.

DESCRIPTION OF DRAWINGS - The drawing shows the reservoirs and pump in the body of the iron.

- Iron (1)
- Soleplate (2)
- Body (3)
- Handle (4)
- Water reservoir (5)
- Textile additive reservoir (12)
- Pump (15)
- Pulverizing sprayer (16)
- Mixing chamber (20)

DWPI selected drawing image.

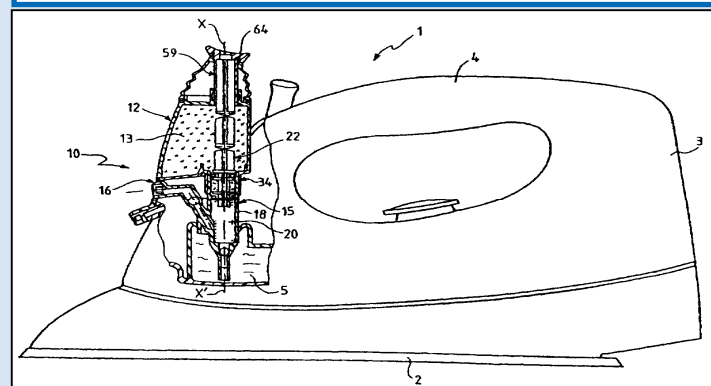

MC EPI: X27-D03

Member(0006)

TIEN Iron comprising a pump for water/textile additive mixture

DWPI records include original title, abstract, and claim(s) for several authorities.

Member(0006)

ABEN The invention concerns an iron comprising a water reservoir ( 5 ), an additive reservoir ( 12 ), and a pump ( 15 ) comprising a mixing chamber ( 20 ) capable of sucking into the mixing chamber a dose of water and a dose of additive via an additive proportioning tap ( 34 ), so as to produce in the mixing chamber a diluted additive solution, and of conveying said solution towards a sprayer ( 16 ). The invention is characterized in that the pump ( 15 ) is of the piston type mobile in a body ( 18 ) and defining the mixing chamber ( 20 ) which emerges into the water reservoir ( 5 ) via a non-return valve, and said pump ( 15 ) also serves as additive proportioning tap ( 34 ). )

Member(0006)

CLMEN US 6671985 B2 UPCL 20060117

What is claimed is:

1. An iron comprising:

a water reservoir ( 5 ); an additive reservoir ( 12 ) containing a textile additive; and a pump ( 15 ) comprising a mixing chamber ( 20 ), said pump being operable for aspirating into the mixing chamber ( 20 ) a dose of water from the water reservoir ( 5 ) as well as of additive from the additive reservoir ( 12 ) via a tap ( 34 ) for permitting dosing of the additive, in a manner to produce in the mixing chamber ( 20 ) a diluted solution of the additive, and said pump being operable for delivering the diluted solution toward a spraying device ( 16 ) situated in a forward part of the iron, wherein the pump ( 15 ), the additive reservoir ( 12 ) and the spraying device ( 16 ) constitute a unitary body that is removably mounted in the iron ( 1 ).

The title, abstract and main (1<sup>st</sup>) claim text from the U.S. granted patent family member are shown on this slide.

# Agenda

- What is the Derwent Word Patents Index (DWPI) and why should I use it ?
  - the value of value-add
- A tour through a typical database record
  - Invention and member levels
- **Keyword/text searching**
- Assignees & Inventors
- Patent/application numbers
  - Dates & authorities

# DWPI text search tips

- Add plurals and DWPI abbreviations
  - => SET PLURALS ON
  - => SET ABBREVIATIONS ON
- Add English spelling variations
  - E.g. color/colour; diaper/nappy
  - => SET SPELLINGS ON
- Use left and right truncation
  - => S ?ANALY?
- Organize answer sets by relevance
  - => FOCUS L1
- Include the Basic Index Extension (/BIEX)
  - => SET SFIELDS BI BIEX

STN Online and Results - [STN-K]

File Edit Online Query Results Preferences! Web Window Help

⇒ SET PLURALS ON  
SET COMMAND COMPLETED

⇒ S ENERGY  
457923 ENERGY  
4658 ENERGIES  
L1 459435 ENERGY  
(ENERGY OR ENERGIES)

⇒ SET ABBREV ON  
SET COMMAND COMPLETED

⇒ S MANUFACTURE  
974618 MANUFACTURE  
8583 MANUFACTURES  
977898 MANUFACTURE  
(MANUFACTURE OR MANUFACTURES)  
271 MANUF  
6 MANUFS  
276 MANUF  
(MANUF OR MANUFS)  
278572 MFR  
462 MFRS  
278856 MFR  
(MFR OR MFRS)  
L2 1071800 MANUFACTURE  
(MANUFACTURE OR MANUF OR MFR)

⇒

Discover! WPINDEX INS Hold Off Print Off Online

Abbreviations and plurals searching are customized to each STN file: DWPI terminology is used to search DWPI.

STN Online and Results - [STN-K]

File Edit Online Query Results Preferences! Web Window Help

85087 SULFUR?  
109212 SULPHUR?  
179870 SULFUR?  
(SULFUR? OR SULPHUR?)

?ANESTHETIZ?  
1927 ?ANESTHETIZ?  
853 ?ANAESTHETIS?  
433 ?ANAESTHETIZ?  
171 ?ANESTHETIS?  
3333 ?ANESTHETIZ?  
(?ANESTHETIZ? OR ?ANAESTHETIS? OR ?ANAESTHETIZ? OR ?ANESTHETIS?)

AEROPLANE?  
7181 AEROPLANE?  
12966 AIRPLANE?  
17074 AEROPLANE?  
(AEROPLANE? OR AIRPLANE?)

WINDSHIELD?  
9586 WINDSHIELD?  
19966 WINDSCREEN?  
24490 WINDSHIELD?  
(WINDSHIELD? OR WINDSCREEN?)

Discover! Transcript: WPINDEX INS Hold Off Print Off Online

**SET SPELLINGS**  
automatically incorporates  
common English spelling  
variations from around the  
world into the search.



STN Online and Results - [STN-K]

File Edit Online Query Results Preferences! Web Window Help

=> S ANALY?  
L1 362688 ANALY?

=> S ?ANALY?  
L2 364032 ?ANALY?

=> S L2 NOT L1  
L3 1344 L2 NOT L1

=> D KWIC

L3 ANSWER 1 OF 1344 WPINDEX COPYRIG  
TI Booting securing method for internet protocol TV terminal system, involves performing **cryptanalysis** and integrity authentication, after loading operating system, file system and application key respectively  
NOV NOVELTY - The method involves performing a **cryptanalysis** and integrity authentication of a boot loader and system keys. The **cryptanalysis** and integrity authentication are performed, after loading an operating system (OS), file system and an application key respectively. Decryption is. .  
ADV. . . . The method efficiently loads the operating system (OS), file system, and the application key during system booting and performs the **cryptanalysis** and integrity authentication of each of the OS, the file system, and the application, thus securing the stability of the.. . .

=> \_

Discover! Transcript: WPINDEX INS Hold Off Print Off Online

Left hand search term truncation.

KWIC is a useful low-cost display format for scanning DWPI search results.

24

STN Online and Results - [STN-K]

File Edit Online Query Results Preferences! Web Window Help

(EMAIL OR EMAILS)  
19205 ELECTRONIC MAIL  
(ELECTRONIC MAIL OR EMAIL)  
L1 6541 (MOBILE OR CELLULAR OR CELL) (W) (PHONE OR TELEPHONE) AND (E MAIL OR EMAIL OR ELECTRONIC MAIL)

=> FOCUS L1  
PROCESSING COMPLETED FOR L1  
L2 6541 FOCUS L1 1-

=> D BRIEF

L2 ANSWER 1 OF 6541 WPINDEX COPYRIGHT  
AN 2002-515150 [55] WPINDEX  
DNN N2002-408016 [55]  
TI Electronic mail advertisement delivery system using internet, transmits advertisement data registered in database to mobile telephones as e-mail during transmission of e-mail between mobile telephones by e-mail server  
DC T01  
PA (MASU-I) MASUDA Y  
AB JP 2002170043 A UPAB: 20050526  
NOVELTY - The system delivers registered advertisement data in a database (111) to mobile telephones (12a,12b) as e-mail, when an e-mail server (11) transmits the e-mail received from the mobile telephone (12a) to another mobile telephone (12b).  
USE - For delivery of advertisement as e-mail to mobile telephones through internet.  
ADVANTAGE - The e-mail advertisement delivery system increases the number of users of internet, as the charge for internet usage is

The FOCUS command re-sorts the answer set by relevance.

BRIEF is a useful DWPI display format for reviewing answers.

Discover! Transcript: WPINDEX INS Hold On Print Off Online

25

# The DWPI default Basic Index (/BI) is formed from value-added text fields

Basic Index  
**/BI**

<b>AN</b>	1999-265576
<b>PI</b>	EP913216 A1 CA2251524 A1 CN1219449 A ...
<b>MEMBER 1</b>	EP913216 A1
<b>MEMBER 2</b>	CA2251524 A1
<b>MEMBER 3</b>	CN1219449 A

**invention part**  
value-added text  
*Title, Abstract*

**members part**  
original text  
*Title, Abstract,  
Main Claim*

---

Basic Index  
Extension  
**/BIEX**

## A search can be extended to include DWPI member level text with BIE X

- On STN it is possible to search DWPI value-added and original patent text separately or simultaneously
- Incorporating the Basic Index Extension (/BIE X) into a DWPI search can improve comprehensiveness

```
=> S OPTICAL(W)FIBRE AND CABLE
```

```
L1          19024 OPTICAL(W)FIBRE AND CABLE
```

```
=> SET SFIELDS BI BIE X PERM
```

```
SET COMMAND COMPLETED
```

SET SFIELDS can be used to change the default search index.

```
=> S OPTICAL(W)FIBRE AND CABLE
```

```
L2          22297 OPTICAL(W)FIBRE/BI,BIE X AND CABLE/BI,BIE X
```

# Popular DWPI display formats

<b>D SCAN</b>	Random title (free)
<b>D TRIAL</b>	Title (or Title Terms*) & codes (free)
<b>D KWIC</b>	Keywords In Context
<b>D BRIEF</b>	Title, assignee, abstract
<b>D BIB</b>	Title, assignee, patent family
<b>D FULLG</b>	BIB + Abstract(s), drawing image
<b>D MEMBB</b>	Applicant title, abstract and claim(s); agent, assignee and inventor details

**Note:** indented (full field description) versions of several formats are available, e.g. [IBIB](#), [IFULLG](#). See [HELP FORMAT](#) for further details.

(\* The DWPI title is included free-of-charge in WPIDS/WPIX. Title Terms in WPINDEX.)

# Classification searching

- DWPI Classification (/DC)
- DWPI Manual Codes (/MC)
- International Patent Classification (/IPC)
- European Patent Classification (/EPC)
- USPTO National Classification (/NCL)
- Japanese Patent Office FI-Terms (/FCL)
- Japanese Patent Office F-Terms (/FTRM)

**Note:** this introductory e-Seminar only reviews DC, MC and IPC.

# DWPI Classification

- A broad classification system assigned by Thomson Reuters uniquely to DWPI
- 2 Level Hierarchy
- Top level split into 21 Sections (A-X)
- Searchable at two levels:
  - => S Q/DC ( Section Level )
  - => S Q18/DC ( Subsection Level )
- Expand /DC to see definition online
- DCs are searchable in DWPI back to 1970

# DWPI Manual Codes

- An in-depth classification system assigned by Thomson Reuters uniquely to DWPI
- Covers basic patent publications in chemical/life science and engineering subject areas
- Chemical/life science codes (A-N) are only searchable in WPIDS/WPIX back to 1963
- Electrical/electronic codes (S-X) are searchable by all users of DWPI back to 1980
- More recently added Mechanical codes (Q), are searchable by all users of DWPI back to 2005

# Example: why use classification in DWPI?

=> S (ANTILOCK? OR ANTI-LOCK?)(2W)BRAK? OR ABS

L1 27515 (ANTILOCK? OR ANTI-LOCK?)(2W)BR

=> S L1 AND (X22 OR Q18)/DC,MC

Q18 BRAKE SYSTEMS; STEERING SYSTEMS; CONTROL

X22 AUTOMOTIVE ELECTRICS

L2 7380 L1 AND (Q18 OR X22)/DC,MC

=> S L1 NOT L2

L3 20135 L10 NOT L11

=> D KWIC 1-

L3 ANSWER xx OF 20135 WPINDEX COPYRIGHT

TECH . . . The case structure of light emitting module is made of acrylonitrile-butadiene-styrene (ABS) material.

L3 ANSWER xx OF 20135 WPINDEX COPYRIGHT 2010 THOMSON REUTERS on STN

TECH . . . protein is selected from ovalbumin, single chain antibodies (Abs) and toxins. The carrier protein is an immunoglobulin . . .

L3 ANSWER xx OF 20135 WPINDEX COPYRIGHT 2010 THOMSON REUTERS on STN

NOV . . . follows the air bearing surface (ABS) of a return yoke (400).

Classification can help limit a text search to an appropriate area of technology.

In this example, the term 'ABS' is ambiguous; a problem that can be solved by using classifications.

Many false answers (L3) are avoided by using classification.

# International Patent Classification

- In-depth classification assigned by patent offices around the world
- 5 level hierarchy covering all technologies
- Top level split into 8 sections (A-H)
- DWPI Format
  - ANNA-NNNN/NNN /IPC
- STN format
  - ANNANNNN-NNN /IPC
- IPCs are searchable in DWPI back to 1963

**Note:** an online IPC thesaurus is available in all STN patent files.

# Example: IPC classification thesaurus

Extensive Classification Thesauri options in DWPI allow you to quickly identify classification symbols.

=> E ABS/IPC 5

E#	FREQUENCY	AT	TERM
--	-----	--	----
. . .			
E2	0	1	ABRASIVE(S) * ABRASIVE(S)/IPC
E3	0	-->	ABS/IPC
E4	0	1	ABS (ANTILOCK BRAKING SYSTEM)/IPC
E5	0	1	ABSORBENTS/IPC

=> E E4+KT

E1	0	-->	ABS (Antilock Braking System)/IPC
E2	395	KT	B60T0008-176/IPC
***** END *****			

Enter **HELP THESAURUS** and **HELP RCODE** at the STN prompt (=>) in WPINDEX to learn more.

=> E E2+ED

E1	395	-->	B60T0008-176/IPC
. . Brake regulation specially adapted to prevent excessive wheel slip during vehicle deceleration, e.g. <b>ABS</b> (B60T0008-1755 takes precedence)			
ADVANCED			
VALID FROM 20060101 TO PRESENT ( IPC EDITION: 8 )			
***** END *****			

=> S E1+NT

L1	4657	B60T0008-176+NT/IPC	( 6 TERMS )
----	------	---------------------	-------------

# Agenda

- What is the Derwent Word Patents Index (DWPI) and why should I use it ?
  - the value of value-add
- A tour through a typical database record
  - Invention and member levels
- Keyword/text searching
- **Assignees & Inventors**
- Patent/application numbers
  - Dates & authorities

# Patent Assignees (PA) and Codes (PACO)

- Basic standardization of original names (/PA)
  - 50+ years of standardization
- 21,000+ standard assignee codes (/PACO)
  - Including codes for Japanese assignee names
- Patent Assignee Codes printed manual
- Web look-up facility (link below)
- STN online thesaurus

Patent Assignee Codes Lookup Facility:

<http://scientific.thomsonreuters.com/support/patents/dwpioref/reftools/companycodes/lookup/>

# Example: Patent Assignees (/PA)

```
=> E APPLE /PA 25
E1          2      APPLD PHYSICS PROBL/PA
E2          1      APPLD TECHN ASSOC I/PA
E3         4468 --> APPLE/PA
E4          1      APPLE ADHESIVES/PA
E5          1      APPLE ARCHERY PROD LLC/PA
E6          1      APPLE BLOSSOM LLC/PA
E7          2      APPLE C L/PA
E8          1      APPLE CAR SALES KK/PA
E9          1      APPLE CO LTD/PA
E10         1      APPLE COMPUTER CO LTD/PA
E11         9      APPLE COMPUTER CORP/PA
E12         1      APPLE COMPUTER FRAN/PA
E13         1      APPLE COMPUTER FRANCE SARL/PA
E14        2310    APPLE COMPUTER INC/PA
E15         1      APPLE COMPUTER INC A CALIFORNIA/PA
E16         4      APPLE COMPUTER LTD/PA
E17         1      APPLE COMPUTER US/PA
E18        11     APPLE COMPUTERS INC/PA
E19         4      APPLE CORP/PA
E20         1      APPLE CORP KK/PA
E21         3      APPLE CORP TECHNOLOGIES INC/PA
E22         1      APPLE CORP YG/PA
. . . .
```

Here we are use Expand to look for DWPI patent family records assigned to Apple (of iPod® fame).

Browse Patent Assignee name variations using the EXPAND command.

# Example: Patent Assignees (/PA) (cont.)

=> E 25

E26	2	APPLE DYNAMICS INTELLECTUAL PROPERTY LTD/PA
E27	2	APPLE E G/PA
E28	4	APPLE ENG LTD/PA
E29	1	APPLE ESSENCE CO LTD/PA
E30	1	APPLE G D/PA
E31	1	APPLE G L/PA
E32	1	APPLE H C/PA
E33	1	APPLE H P/PA
E34	1	APPLE HOUSE ELECTRONICS LTD/PA
E35	2372	APPLE INC/PA
E36	5	APPLE IRYO KIKI KK/PA
E37	2	APPLE J/PA
E38	1	APPLE J A/PA
E39	1	APPLE J L/PA
E40	1	APPLE J R/PA
E41	5	APPLE JU STUDIO INC/PA
E42	1	APPLE KENSETSU KK/PA
E43	11	APPLE KK/PA
E44	2	APPLE L/PA
E45	1	APPLE M/PA
. . . .		

Browse Patent Assignee name variations using the EXPAND command.

# Example: Patent Assignees (/PA) (cont.)

=> S E9-E22,E35

L1 4308 ("APPLE CO LTD"/PA OR "APPLE COMPUTER CO LTD"/PA OR "APPLE  
COMPUTER CORP"/PA OR . . . "APPLE CORP"/PA  
KK"/PA OR "APPLE CORP TECHNOLOGIES INC"/PA  
YG"/PA OR "APPLE INC"/PA)

Search items of  
interest from the  
EXPAND list.

=> D BIB

L1 ANSWER 1 OF 4308 WPINDEX COPYRIGHT 2010 THOMSON REUTERS on STN  
AN 2010-K30625 [201055] WPINDEX  
TI Method for providing emergency call within network i.e. third  
generation partnership project internet protocol multimedia core  
network sub-system compliant cellular network, involves transmitting  
composite stream via session  
DC T01; W01  
IN HANS M  
PA (APPY-C) APPLE INC; (HANS-I) HANS M  
CYC 125  
PIA US 20100202368 A1 20100812 (201055)\* EN 26[6]  
WO 2010093646 A1 20100819 (201055) EN  
ADT US 20100202368 A1 US 2009-368947 20090210; WO 2010093646 A1 WO  
2010-US23680 20100209  
PRAI US 2009-368947 20090210

# Example: Patent Assignee Codes (PACO)

=> E APPLE/PACO

E#	FREQUENCY	AT	TERM
--	-----	--	----
E1	0	1	APPLAUSE SYSTEM KK/PACO
E2	0	1	APPLD/PACO
E3	0	18 -->	APPLE/PACO
E4	0	1	APPLE & FRIENDS DESIGN PTE LTD/PACO
E5	0	1	APPLE ARCHERY PROD LLC/PACO
E6	0	1	APPLE BLOSSOM LLC/PACO
E7	0	1	APPLE CAR SALES KK/PACO
E8	0	1	APPLE CO LTD/PACO
E9	0	1	APPLE COMPUTER CO LTD/PACO
E10	0	1	APPLE COMPUTER CORP/PACO
E11	0	1	APPLE COMPUTER FRANCE SARL/PACO
E12	0	1	APPLE COMPUTER INC/PACO

To identify the appropriate code EXPAND the name in the field /PACO.

=> E E9+ALL

E1	0	-->	APPLE COMPUTER CO LTD/PACO
E2	4299		CODE APPY-C/PACO
***** END *****			

Open the thesaurus using the relationship code +ALL.

# Example: PACO (cont.)

=> E E2+DEF

```
E1      4299    -->  APPY-C/PACO
E2      DEF     APPLE COMPUTER CO LTD/PACO
E3      DEF     APPLE COMPUTER CORP/PACO
E4      DEF     APPLE COMPUTER FRANCE SARL/PACO
E5      DEF     APPLE COMPUTER INC/PACO
E6      DEF     APPLE COMPUTER LTD/PACO
E7      DEF     APPLE COMPUTERS INC/PACO
E8      DEF     APPLE INC/PACO
```

\*\*\*\*\* END \*\*\*\*\*

Use the relationship code **+DEF**, to see the definition of the code.

These are the name variations covered by the APPY-C code.

=> S E1

L2 4299 APPY-C/PACO

**Note:** searching by name (L1) retrieved more documents than by code (L2).

=> D AN TI PA PN

```
L2      ANSWER 1 OF 4299  WPINDEX COPYRIGHT 2010          THOMSON REUTERS on STN
AN      2010-K30625 [201055]  WPINDEX
TI      Method for providing emergency call within network i.e. third
        generation partnership project internet protocol multimedia core
        network sub-system compliant cellular network, involves transmitting
        composite stream via session
PA      (APPY-C) APPLE INC; (HANS-I) HANS M
PI      US 20100202368  A1 20100812 (201055)* EN  26[6]
        WO 2010093646  A1 20100819 (201055)  EN
```

# Example: PACO (cont.)

=> S L1 NOT L2

L3 10 L1 NOT L2

10 additional documents (L3) were retrieved in the name search (L1).

=> D TI PA PN

L3 ANSWER 1 OF 10 WPINDEX COPYRIGHT 2010

THOMSON REUTERS on STN

TI Connector for mannequin

PA (APPL-N) APPLE CORP

PI TW 323855 U 20071221 (200966)\* ZH 0

The 10 records come from an unrelated Apple company.

=> S L2 NOT L1

L4 1 L2 NOT L1

We also missed one relevant document (L4) not found in the name search (L1).

=> D TI PA PN

L4 ANSWER 1 OF 1 WPINDEX COPYRIGHT 2010

TI Operand permutation with replication performance register file for multimedia and scientific modeling

PA (APPY-C) APPLE; (IBMC-C) IBM CORP; (MOTI-C) MOTOROLA INC

PI US 5996057 A 19991130 (200006)\* EN 11[8]

Searching with Patent Assignee Codes is typically more precise and more comprehensive.

# Patent Assignee Codes

- Standard versus Non-Standard
  - STANDARD                      AAAA-C
  - NON-STANDARD                AAAA-N
  - SOVIET INSTITUTES        AAAA-R
  - INDIVIDUALS                    AAAA-I

Do not use *non-standard codes* for searching!

# Searching for Inventors

- Inventors /IN (or /AU)
- Inventors from the DWPI basic document
- Available from 1978
- Surname Initials format, e.g. SMITH J/IN
- Inventors (/IN) for Japanese documents are included from June 2005 onwards

**Note:** full non-standardized inventor names are searchable for US, EP, DE, WO and JP family members in the Inventor Original (/INO) field.

# Example: Inventor search (/IN)

```
=> E SMITH J/IN 5
E1          1      SMITH IV F J/IN
E2          2      SMITH IV O J/IN
E3         794 --> SMITH J/IN
E4         427      SMITH J A/IN
E5          2      SMITH J A A B U L/IN
```

Here we are using Expand to look for the inventor Jason Smith, using surname and initial letter, in the standardized inventor (/IN) field.

```
=> S E3
```

```
L1          794 "SMITH J"/IN
```

```
=> D AN TI IN INO
```

```
L1  ANSWER 1 OF 794  WPINDEX COPYRIGHT 2010          THOMSON REUTERS on STN
AN  2010-J75351 [201051]  WPINDEX
TI  Method for controlling load e.g. air handler in heating ventilating or
    air conditioning system, involves controlling switch between load and
    primary/back up power supplies by implementing control algorithm in
    intelligent controller
IN  SMITH J; WARREN D
```

```
Member(0001)
```

```
INO  Warren, Donald; Smith, John
```

Unfortunately, there are rather a lot of hits for "John Smith"!

# Example: Inventor Original search (/INO)

```
=> E SMITH JASON/INO 5
E1          3      SMITH JARRED/INO
E2          1      SMITH JARRED A/INO
E3         29 --> SMITH JASON/INO
E4         17      SMITH JASON A/INO
E5          2      SMITH JASON ALAN/INO
```

```
=> S E3
```

```
L2          29 "SMITH JASON"/INO
```

```
=> D AN TI IN INO
```

```
L2  ANSWER 1 OF 29  WPINDEX COPYRIGHT 2010          THOMSON REUTERS on STN
AN  2010-J64546 [201054]  WPINDEX
TI  After-market container or carrier for use in golf cart for sequential
    dispensing of golf ball has fasteners connecting first and second
    mating members in engaged relation
IN  SMITH J
```

```
Member(0001)
INO Smith, Jason
```

Here we are using Expand to look for the inventor Jason Smith, using surname and first name, in the Inventor Original (/INO) field.

**Note:** although useful, the INO field is only available for a restricted list of patent authorities (see slide 44).

# Agenda

- What is the Derwent Word Patents Index (DWPI) and why should I use it ?
  - the value of value-add
- A tour through a typical database record
  - Invention and member levels
- Keyword/text searching
- Assignees & Inventors
- **Patent/application numbers**
  - Dates & authorities

# Numbers and Dates

- Publication Numbers and dates (PN, PD)
  - => S EP1116932/PN
  - => S 20010718/PD
- Application Numbers and dates (AP, AD)
  - => S EP2000-126646/AP
  - => S 20001205/AD
- Priority Numbers and dates (PRN, PRD)
  - => S US2000-176284/PRN
  - => S 20000114/PRD

# Publication numbers (PN)

- STN has automatic search edits to handle many common formats, e.g. with commas or slashes
- Take out any periods and the publication kind code; include the 2-digit country code prefix
- Continuous series
  - Search U.S. 4,718,426 **A**, as => **S US 4,718,426/PN**
- Annual series
  - Search WO 99/12345 **A1**, as => **S WO 99/12345/PN**
  - Search WO 03/04255 **A2**, as => **S WO 03/04255/PN**

# Application and priority numbers (AP, PRN)

- Take out all commas, slashes, periods, suffixes and prefixes (including U.S. series); use the 2-digit country code prefix, and application year
- United States application 9/101,138 2000  
=> S US2000-101138/AP
- US provisional application (series 60 and 61) priority numbers have a P appended, e.g.  
=> S US2003-440129P/PRN
- Coverage of application numbers (AP) is complete from DWPI update 199216 onwards

**Note:** supplementary application numbers (APTS) are also available.

# Date fields and examples

Publication Date (PD)	=> S 1 MAY 2004/PD
Publication Year (PY)	=> S 1998 - 1999/PY
Publication Date <u>Basic</u>	=> S JAN - FEB 2007/PD. <b>B</b>
Publication Year <u>Basic</u>	=> S PY. <b>B</b> > 2000
Application Date (AD)	=> S MARCH 1993/AD
Application Year (AY)	=> S AY < 1991
Priority Date (PRD)	=> S APRIL 1, 1995/PRD
Priority Year (PRY)	=> S 1987/PRY
Priority Date <u>First</u>	=> S 19780401/PRD <b>F</b>
Priority Year <u>First</u>	=> S PRY <b>F</b> >= 1975

# Country (authority) fields and examples

Publication Country (PC)	=> S US/PC
Publication Country <u>Basic</u>	=> S WO/PC.B
Publication Kind (PK)	=> S USB2/PK
Publication Kind <u>Basic</u>	=> S EPA1/PK.B
Application Country (AC)	=> S GERMANY/AC
Priority Country (PRC)	=> S DE/PRC
Designated States	=> S GB/DS
Same family member	=> S EPB1/PK (P) 1998/PY

For details of publication kind (PK) covered in Derwent World Patents Index (DWPI) type [HELP KIND](#) and the STN prompt (=>).

# Review: What is DWPI “value-add”?

- Enhanced patent titles and abstracts
  - Improve search recall and relevance
  - Reduce time required to review results
- Intellectually compiled patent families
  - Precise access to equivalent documents
  - Reduce time required to review results
- Comprehensive classification and indexing
  - Provides multiple methods to pinpoint documents
  - Improves search recall and relevance

# Summary

- What is the Derwent Word Patents Index (DWPI<sup>SM</sup>) and why should I use it ?
  - the value of value-add
- A tour through a typical database record
  - Invention and member levels
- Keyword/text searching
- Assignees & Inventors
- Patent/application numbers
  - Dates & authorities

# Resources

- DWPI on STN User Documentation
  - [http://www.stn-international.com/stn\\_dwpi.html](http://www.stn-international.com/stn_dwpi.html)
  - DWPI on STN Reference Manual
  - DWPI on STN Workshop Manual
  - DWPI Classification (DC) guide
  - Summary table of member level data coverage
  - Global Patent Sources – DWPI coverage in detail
  - Chemistry, Engineering and Polymer User Guides
- DWPI on STN database summary sheet
  - <http://www.stn-international.com/wpindex.html>

# STN<sup>®</sup>

For more information ...

CAS

E-mail: [help@cas.org](mailto:help@cas.org)

Support and Training:

[www.cas.org](http://www.cas.org)

FIZ Karlsruhe

[helpdesk@fiz-karlsruhe.de](mailto:helpdesk@fiz-karlsruhe.de)

Support and Training:

[www.stn-international.de](http://www.stn-international.de)