

Introduction to Derwent World Patents Index[®] (DWPI)

STN[®]

Jim Brown

FIZ Karlsruhe, Inc.

Agenda

- What is the Derwent Word Patents Index (DWPISM) and why should I use it ?
 - the value of value-add
- A tour through a typical database record
 - Invention and member levels
- Keyword/text searching
- Assignees & Inventors
- Patent/application numbers
 - Dates & authorities
- Derwent World Patents Index First View

What is Derwent World Patents Index?

- The largest value-added patent database
 - Covers over 40 patenting organizations
- An index of global patent publications
 - Concise patent families
 - Enhanced English titles and abstracts
 - Patent Assignee Codes
 - Classification and Indexing
- Produced by Thomson Reuters

Why should I use it?

- For all patent searches with high commercial relevance, it is essential to search all value-added patent databases and complement the results with first-level patent data

Why should I use it?

- Patent information users greatly benefit from intellectually analyzed patent database content
 - Enables efficient retrieval with highly relevant results
 - Searching value-added patent databases is indispensable for a comprehensive search result
- STN has the complete offering on a single, professional search platform

What is first-level patent data?

- Information derived only from the original publication of the document
 - Full-text databases deriving from electronic input (e.g., EPFULL) or generated by OCR techniques (e.g., PCTFULL)
 - Bibliographic databases from national offices (e.g., KOREAPAT)
 - Bibliographic databases with international coverage (INPAFAMDB, INPADOCDB)

What is “value-add” in a patent database?

- Based on the original patent publications, a newly written database record is created (with extensive quality checks) to facilitate retrieval
 - An enhanced meaningful **title** and patent-focused **abstract** to reveal the actual invention
 - A high-quality **bibliography** that summarizes all publication details for a particular invention
 - **Combination** of all family members, including non-conventional equivalents (as in DWPISM)

What is “value-add” in a patent database? (cont.)

- Based on the original patent publications, a newly written database record is created (with extensive quality checks) to facilitate retrieval
 - Additional summaries of the described technology (e.g., “TECH” abstract in DWPI, “ABEX” extension abstracts in WPIX)
 - Additional assignment of classifications, categories, or controlled terminology (e.g., Manual Codes)

What is “value-add” in a patent database?

(cont.)

- Based on the original patent publications, a newly written database record is created (with extensive quality checks) to facilitate retrieval
 - Standardization of company names (e.g., PACO in DWPI)

How to access DWPI on STN?



Desk-top software providing classic online access, with Web links and search assistants. Includes efficient post-processing and analysis tools for **reports, charts & tables**



<http://stneasy.fiz-karlsruhe.de>

Easy-to-use web access for occasional, basic searches



<http://stnweb.fiz-karlsruhe.de>

Browser based online access for professional searchers with the benefits of the Web

How to access DWPI on STN? (cont.)

- **FILE WPINDEX** (open access database)
- **FILE WPIDS** (subscriber database)
- **FILE WPIX** (subscriber database with Extension Abstracts)
- **FILE LWPI** (The DWPI learning file)
- **FILE WPIFV** (The DWPI First View preview database)

DWPI subject coverage

- 1963 Pharmaceuticals
- 1965 Agriculture Chemicals
- 1966 Plastics & Polymers
- 1970 Rest of Chemistry
- 1974 All technologies

Agenda

- What is the Derwent Word Patents Index (DWPISM) and why should I use it ?
 - the value of value-add
- A tour through a typical database record
 - Invention and member levels
- Keyword/text searching
- Assignees & Inventors
- Patent/application numbers
 - Dates & authorities
- Derwent World Patents Index First View

DWPI records have two levels

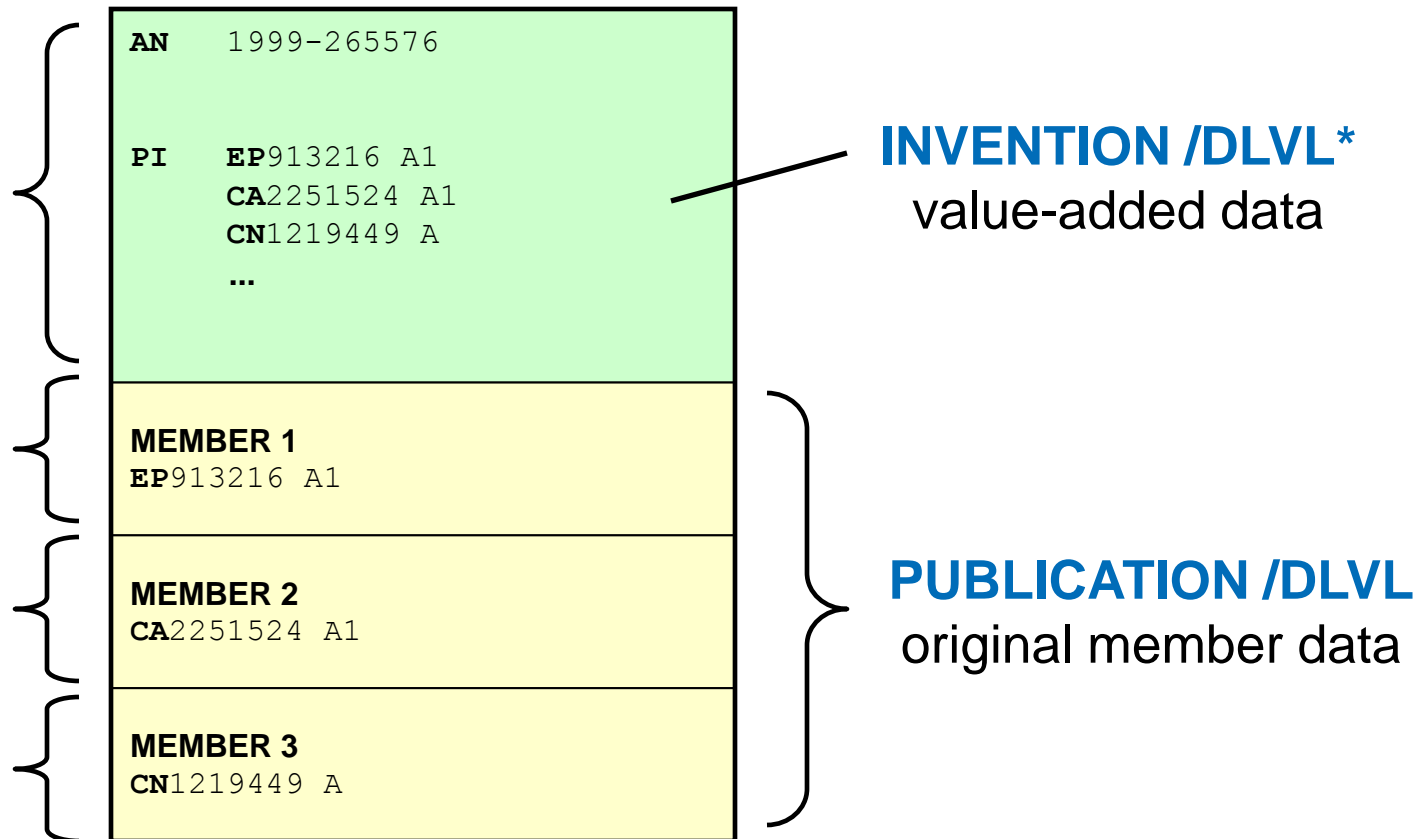

DLVL = Document Level. Options are INVENTION /DLVL or PUBLICATION /DLVL

DWPI Invention Level Data

- Patent family data
- Thomson Reuters value added data
 - Enhanced title and abstract
- Deduplicated assignee and inventor data
- Deduplicated classes
- In-depth indexing

DWPI Member Level Data

- Original titles, abstracts & main (1st) claim
- Full inventor names and addresses
- Original assignee names and addresses
- Attorney/agent names and addresses
- Application and priority number backfile
- WO, EP, US, JP, GB, DE, AU, CN, TW, RU
 - Different members have different amounts of data

Member (publication) data can be displayed using individual fields, e.g. Claims-in-English (CLMEN), or the Member (MEMB), Member Brief (MEMBB) and Member Full (MEMBF) formats. Note that Member data is not included in Invention displays such as ALL, FULL, MAX, etc.

Summary Table of First Level Data in DWPI Member Level Record

Patent Authority	Type: Kind Codes	Original Title	Original Abstracts	Main Claim	All Claims	Inventor Full Name and Address	Original Assignee Name and Address	Legal Rep/Agent Name and Address
WIPO/PCT	Applications: A1,2,3,4,8,9	1978+	1978+			1999+	1978+	1999+
European Patent Office	Applications and Granted Patents: A1, A2, B1, B2	1978+ (English, French, German)	1978+ (English); 2000+ (French, German)	1984+ (B1/B2 only); 1991+ (all kinds)		1978+	1978+	1978+
Australia	Applications: A1,4,8; B1,2	2004+						2009+
Germany	Applications, Granted Patents & Utility Models: A1, B1, B2, B3, B4, C1, C2, U1	1968+	2000+	1968+		1968+	1968+	1968+
Japan	Applications, Granted Patents & Utility Models: A, B, U	1975+ (A only - Machine Assisted Translation); Granted patents and Utility Models from DWPI Update 200824	DWPI Update 200824+ (Machine Assisted Translation)	DWPI Update 200824+ (Machine Assisted Translation)		1977 to 2006 (Applications - name only, no addresses); Applications, granted patents and Utility Models from 200901 (name only)	1977 to 2006 (Applications - name only, no addresses)	
United Kingdom	Granted Patents: B	2004+		1984-1997				
United States	applications & Granted Patents: A, A1, B1, B2	1975+	1975+	1993+		1975+	1975+	1975+
Russia	C1, C2, C9	2009+	2009+					
France	A1, A3	2009+	2009+					2009+
India	I1-4; P1-4	2009+	2009+ (I1-I4)					
China	Applications & Utility Models - A, Y	June 2007 (Human Translation)	June 2007 (Human Translation)	June 2007 (Human Translation)	CN A Jan 2007; CN Y June 2007 (Human Translation)	Applications, granted patents and Utility Models from 200901 (name only)		
Taiwan	Applications, Granted Patents and Utility Models A, B, U	2008+				Applications, granted patents and Utility Models from 200907 (name only)		
South Korea	Applications, Granted Patents and Utility Models A, B, U, Y1	2008+ (Machine Translation)	2008+ (Machine Translation)	2008+ (Machine Translation)	2008+ (Machine Translation)	Applications, granted patents and Utility Models from 200901 (name only)		

Please Note: There may be some records where the original data is not available; Dates are publication dates of the coverage, unless listed as DWPI Update Does not include details of patent classification (ECLA, IPC, US Class, JP F/II terms) as these are included for all relevant authorities in DWPI.

A tour through a typical DWPI record

- Enhanced title
- Assignee and inventor
- Patent family
- Enhanced abstract
- Selected drawing image
- Patent classifications
- Original title and abstract
- Claim(s) text

AN 2001-476126 [51] WPINDEX

TI Iron, for ironing clothes, has water reservoir, textile additive reservoir and piston and valve pump which mixes water and additive in mixing chamber before discharge at front of iron through pulverizer

DC X27

IN BOULEAU J; BOULEAU J P

PA (BOUL-I) BOULEAU J; (MOUX-C) MOULINEX SA; (SEBS-C) SEB SA

PI WO 2001053595 A1 20010726 (200151)* FR 28[9]
 FR 2804137 A1 20010727 (200151) FR
 EP 1248876 A1 20021016 (200276) FR
 US 20030056406 A1 20030327 (200325) EN
 TW 499525 A 20020821 (200333) ZH
 US 6671985 B2 20040106 (200411) EN
 EP 1248876 B1 20040915 (200460) FR
 ES 2225476 T3 20050316 (200525) ES
 RU 2256733 C2 20050720 (200548) RU
 MX 2002006036 A1 20040901 (200553) ES
 MX 232066 B 20051110 (200634) ES

ADT WO 2001053595 A1 WO 2001-FR112 20010115; FR 2804137 A1 FR 2000-874 20000120;
 EP 1248876 A1 EP 2001-903945 20010115; EP 1248876 B1 EP 2001-903945 20010115;
 ES 2225476 T3 EP 2001-903945 20010115; EP 1248876 A1 WO 2001-FR112 20010115;
 US 20030056406 A1 WO 2001-FR112 20010115; US 6671985 B2 WO 2001-FR112 20010115;
 ...

FDT ES 2225476 T3 Based on EP 1248876 A; EP 1248876 A1 Based on WO 2001053595 A;
 US 6671985 B2 Based on WO 2001053595 A; EP 1248876 B1 Based on WO 2001053595 A;
 RU 2256733 C2 Based on WO 2001053595 A; MX 2002006036 A1 Based on
 WO 2001053595 A; MX 232066 B Based on WO 2001053595 A

PRAI FR 2000-874 20000120

DWPI enhanced title.

A tour through a typical DWPI record

- Enhanced title
- **Assignee and inventor**
- Patent family
- Enhanced abstract
- Selected drawing image
- Patent classifications
- Original title and abstract
- Claim(s) text

AN 2001-476126 [51] WPINDEX
 TI Iron, for ironing clothes, has water reservoir, textile additive reservoir
 and piston and valve pump which mixes water and additive in mixing chamber
 before discharge at front of iron through pulverizer
 DC X27
 IN BOULEAU J; BOULEAU J P
 PA (BOUL-I) BOULEAU J; (MOUX-C) MOULINEX SA; (SEBS-C) SEB SA
 PI WO 2001053595 A1 20010726 (200151)* FR 28[9]
 FR 2804137 A1 20010727 (200151) FR
 EP 1248876 A1 20021016 (200276) FR
 US 20030056406 A1 20030327 (200325) EN
 TW 499525 A 20020821 (200333) ZH
 US 6671985 B2 20040106 (200411) EN
 EP 1248876 B1 20040915 (200460) FR
 ES 2225476 T3 20050316 (200525) ES
 RU 2256733 C2 20050720 (200548) RU
 MX 2002006036 A1 20040901 (200553) ES
 MX 232066 B 20051110 (200634) ES
 ADT WO 2001053595 A1 WO 2001-FR112 20010115; FR 2804137 A1 FR 2000-874 20000120;
 EP 1248876 A1 EP 2001-903945 20010115; EP 1248876 B1 EP 2001-903945 20010115;
 ES 2225476 T3 EP 2001-903945 20010115; EP 1248876 A1 WO 2001-FR112 20010115;
 US 20030056406 A1 WO 2001-FR112 20010115; US 6671985 B2 WO 2001-FR112 20010115;
 ...
 FDT ES 2225476 T3 Based on EP 1248876 A; EP 1248876 A1 Based on WO 2001053595 A;
 US 6671985 B2 Based on WO 2001053595 A; EP 1248876 B1 Based on WO 2001053595 A;
 RU 2256733 C2 Based on WO 2001053595 A; MX 2002006036 A1 Based on
 WO 2001053595 A; MX 232066 B Based on WO 2001053595 A
 PRAI FR 2000-874 20000120

Deduplicated inventor and
 assignee info, including
 Derwent's PACOs.

A tour through a typical DWPI record

- Enhanced title
- Assignee and inventor
- **Patent family**
- Enhanced abstract
- Selected drawing image
- Patent classifications
- Original title and abstract
- Claim(s) text

AN 2001-476126 [51] WPINDEX
 TI Iron, for ironing clothes, has water reservoir, textile additive reservoir and piston and valve pump which mixes water and additive in mixing chamber before discharge at front of iron through pulverizer
 DC X27
 IN BOULEAU J; BOULEAU J P
 PA (BOUL-I) BOULEAU J; (MOUX-C) MOULINEX SA; (SEBS-C) SEB SA
 PI WO 2001053595 A1 20010726 (200151)* FR 28[9]
 FR 2804137 A1 20010727 (200151) FR
 EP 1248876 A1 20021016 (200276) FR
 US 20030056406 A1 20030327 (200325) EN
 TW 499525 A 20020821 (200333) ZH
 US 6671985 B2 20040106 (200411) EN
 EP 1248876 B1 20040915 (200460) FR
 ES 2225476 T3 20050316 (200525) ES
 RU 2256733 C2 20050720 (200548) RU
 MX 2002006036 A1 20040901 (200553) ES
 MX 232066 B 20051110 (200634) ES

ADT WO 2001053595 A1 WO 2001-FR112 20010115; FR 2804137 A1 FR 2000-874 20000120;
 EP 1248876 A1 EP 2001-903945 20010115; EP 1248876 B1 EP 2001-903945 20010115;
 ES 2225476 T3 EP 2001-903945 20010115; EP 1248876 A1 WO 2001-FR112 20010115;
 US 20030056406 A1 WO 2001-FR112 20010115; US 6671985 B2 WO 2001-FR112 20010115;
 ...

FDT ES 2225476 T3 Based on EP 1248876 A; EP 1248876 A1 Based on WO 2001053595 A;
 US 6671985 B2 Based on WO 2001053595 A; EP 1248876 B1 Based on WO 2001053595 A;
 RU 2256733 C2 Based on WO 2001053595 A; MX 2002006036 A1 Based on
 WO 2001053595 A; MX 232066 B

PRAI FR 2000-874 20000120

DWPI patent family.

Priority Application Information (PRAI).

A tour through a typical DWPI record

- Enhanced title
- Assignee and inventor
- Patent family
- **Enhanced abstract**
- Selected drawing image
- Patent classifications
- Original title and abstract
- Claim(s) text

IC ICM D06F0075-14
IPCR D06F0075-08 [I,C]; D06F0075-14 [I,A]; D06F0075-22 [I,A]
EPC D06F0075-14; D06F0075-22
NCL NCLM 038/077.500
AB WO 2001053595 A1 UPAB: 20060117

NOVELTY - Iron (1) has soleplate (2), body (3) and handle (4). Within body are water reservoir (5), textile additive reservoir (12), pump (15) and sprayer/pulverizer (16). Pump, which has two plane disks, two perforated disks and two mobile seals, draws water from respective reservoirs and mixes them in mixing chamber (20). Discharge through pulverizing sprayer (16).

USE - For ironing clothes.

ADVANTAGE - The arrangement of reservoirs allows them to be more easily installed into the body of the iron.

DESCRIPTION OF DRAWINGS - The drawing shows the reservoirs and pump in the body of the iron.

Iron (1)

Soleplate (2)

Body (3)

Handle (4)

Water reservoir (5)

Textile additive reservoir (12)

Pump (15)

Pulverizing sprayer (16)

Mixing chamber (20)

MC EPI: X27-D03

The DWPI enhanced abstract provides a concise summary of the claimed invention.

A tour through a typical DWPI record

- Enhanced title
- Assignee and inventor
- Patent family
- Enhanced abstract
- **Selected drawing image**
- Patent classifications
- Original title and abstract
- Claim(s) text

IC ICM D06F0075-14

IPCR D06F0075-08 [I,C]; D06F0075-14 [I,A]; D06F0075-22 [I,A]

EPC D06F0075-14; D06F0075-22

NCL NCLM 038/077.500

AB WO 2001053595 A1 UPAB: 20060117

NOVELTY - Iron (1) has soleplate (2), body (3) and handle (4). Within body are water reservoir (5), textile additive reservoir (12), pump (15) and sprayer/pulverizer (16). Pump, which has two plane disks, two perforated disks and two mobile seals, draws water and additive from respective reservoirs and mixes them in mixing chamber (20) before discharge through pulverizing sprayer (16).

USE - For ironing clothes.

ADVANTAGE - The arrangement of reservoirs and pump is compact and more easily installed into the body of the iron.

DESCRIPTION OF DRAWINGS - The drawing shows the reservoirs and pump in the body of the iron.

Iron (1)

Soleplate (2)

Body (3)

Handle (4)

Water reservoir (5)

Textile additive reservoir (12)

Pump (15)

Pulverizing sprayer (16)

Mixing chamber (20)

MC EPI: X27-D03

DWPI selected drawing image.

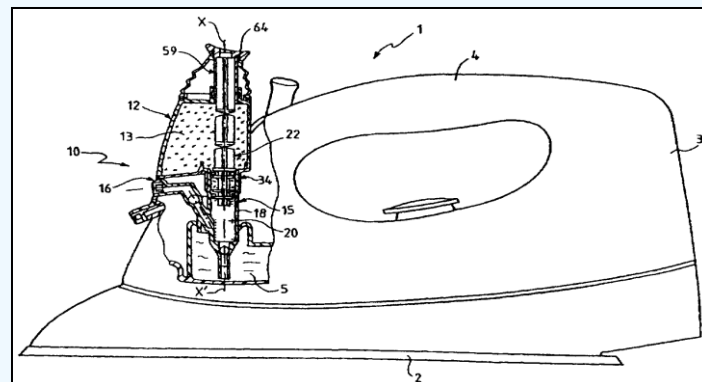

A tour through a typical DWPI record

- Enhanced title
- Assignee and inventor
- Patent family
- Enhanced abstract
- Selected drawing image
- **Patent classifications**
- Original title and abstract
- Claim(s) text

IC ICM D06F0075-14
 IPCR D06F0075-08 [I,C]; D06F0075-14 [I,A]; D06F0075-14 [I,A]
 EPC D06F0075-14; D06F0075-22
 NCL NCLM 038/077.500

AB WO 2001053595 A1 UPAB: 20060117

NOVELTY - Iron (1) has soleplate (2), body (3) and handle (4). Within body are water reservoir (5), textile additive reservoir (12), pump (15) and sprayer/pulverizer (16). Pump, which has two plane disks, two perforated disks and two mobile seals, draws water and additive from respective reservoirs and mixes them in mixing chamber (20) before discharge through pulverizing sprayer (16).

USE - For ironing clothes.

ADVANTAGE - The arrangement of reservoirs and pump is compact and more easily installed into the body of the iron.

DESCRIPTION OF DRAWINGS - The drawing shows the reservoirs and pump in the body of the iron.

Iron (1)

Soleplate (2)

Body (3)

Handle (4)

Water reservoir (5)

Textile additive reservoir (12)

Pump (15)

Pulverizing sprayer (16)

Mixing chamber (20)

MC EPI: X27-D03

U.S., European and International Patent classifications.

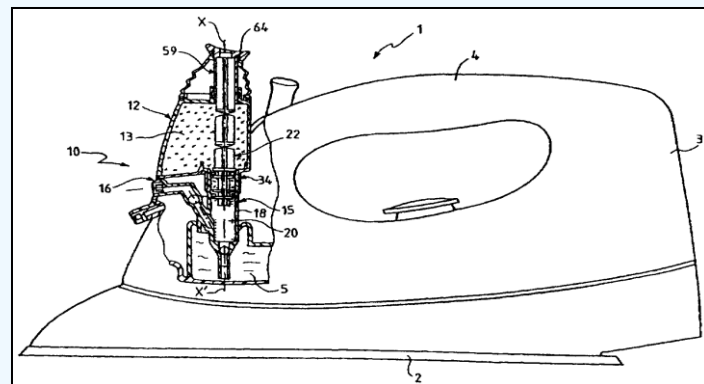

A tour through a typical DWPI record

- Enhanced title
- Assignee and inventor
- Patent family
- Enhanced abstract
- Selected drawing image
- Patent classifications
- Original title and abstract
- Claim(s) text

Member (0006)

TIEN Iron comprising a pump for water/textile additive mixture

Member (0006)

ABEN The invention concerns an iron comprising a water reservoir (5), a textile additive reservoir (12), and a pump (15) comprising a mixing chamber (20) capable of sucking into the mixing chamber a dose of water and a dose of additive via an additive proportioning tap (34), so as to produce in the mixing chamber a diluted additive solution, and of conveying said solution towards a sprayer (16). The invention is characterized in that the pump (15) is of the piston type mobile in a body (18) and defining the mixing chamber (20) which emerges into the water reservoir (5) via a non-return valve, and said pump (15) also serves as additive proportioning tap (34).)

Member (0006)

CLMEN US 6671985 B2 UPCL 20060117

What is claimed is:

1. An iron comprising:

a water reservoir (5); an additive reservoir (12); an additive reservoir (12); and a pump (15) comprising a mixing chamber (20), said pump being operable for aspirating into the mixing chamber (20) a dose of water from the water reservoir (5) as well as of additive from the additive reservoir (12) via a tap (34) for permitting dosing of the additive, in a manner to produce in the mixing chamber (20) a diluted solution of the additive, and said pump being operable for delivering the diluted solution toward a spraying device (16) situated in a forward part of the iron, wherein the pump (15), the additive reservoir (12) and the spraying device (16) constitute a unitary body that is removably mounted in the iron (1).

DWPI original title and abstract from the U.S. granted patent family member are highlighted here.

A tour through a typical DWPI record

- Enhanced title
- Assignee and inventor
- Patent family
- Enhanced abstract
- Selected drawing image
- Patent classifications
- Original title and abstract
- **Claim(s) text**

Member(0006)

TIEN Iron comprising a pump for water/textile additive mixture

Member(0006)

ABEN The invention concerns an iron comprising a water reservoir (5), a textile additive reservoir (12), and a pump (15) comprising a mixing chamber (20) capable of sucking into the mixing chamber a dose of water and a dose of additive via an additive proportioning tap (34), so as to produce in the mixing chamber a diluted additive solution, and of conveying said solution towards a sprayer (16). The invention is characterized in that the pump (15) is of the piston type mobile in a body (18) and defining the mixing chamber (20) which emerges into the water reservoir (5) via a non-return valve, and said pump (15) also serves as additive proportioning tap (34).)

Member(0006)

CLMEN US 6671985 B2 UPCL 20060117

What is claimed is:

1. An iron comprising:
a water reservoir (5); an additive reservoir (12); an additive proportioning tap (34); and a pump (15) comprising a mixing chamber (20), said pump being operable for aspirating into the mixing chamber (20) a dose of water from the water reservoir (5) as well as of additive from the additive reservoir (12) via a tap (34) for permitting dosing of the additive, in a manner to produce in the mixing chamber (20) a diluted solution of the additive, and said pump being operable for delivering the diluted solution toward a spraying device (16) situated in a forward part of the iron, wherein the pump (15), the additive reservoir (12) and the spraying device (16) constitute a unitary body that is removably mounted in the iron (1).

The main (1st) claim text from the U.S. granted patent family member is highlighted here.

What is DWPI value-add?

- Enhanced patent titles and abstracts
 - Improve search recall and relevance
 - Reduce time required to review results
- Intellectually compiled patent families
 - Precise access to equivalent documents
- Comprehensive classification and indexing
 - Improves search recall and relevance

The value of enhanced titles

US006169908B1

(12) **United States Patent**
Mannak

(10) **Patent No.:** **US 6,169,908 B1**
(45) **Date of Patent:** **Jan. 2, 2001**

(54) **TELECOMMUNICATION SYSTEM**

FOREIGN PATENT DOCUMENTS

(75) Inventor: **Jacobine Johannette Mannak**, The Hague (NL)

0 319 210 6/1989 (EP) .
0 514 360 A2 * 4/1992 (EP) H04Q 7/04
0 503 813 9/1992 (EP)

AN 1998-534291 [46] WPINDEX

TI Telecommunications system for combined pager and cellular telephone terminal - includes terminals with pager section that can be detached, transmits to pager section calls from callers who form part of user preferred group.

(22) Filed: Mar. 20, 1998

Peter L. Michaelson

(30) Foreign Application Priority Data

(57) **ABSTRACT**

Mar. 21, 1997 (NL) 1005601

A telecommunication system comprising a telecommunication network apparatus and at least one terminal. The terminal comprises a radiotelephone section and a pager section. The radiotelephone section and the pager section can be uncoupled from and coupled to each other. The

(51) Int. Cl.⁷ H04B 1/16; H04B 1/38; H04Q 7/20; H04Q 5/22; H04M 1/00

(52) U.S. Cl. 455/557; 455/557; 455/575; 455/313; 455/426; 310/825 A1

What is DWPI value-add?

- Enhanced patent titles and abstracts
 - Improve search recall and relevance
 - Reduce time required to review results
- **Intellectually compiled patent families**
 - Precise access to equivalent documents
- Comprehensive classification and indexing
 - Improves search recall and relevance

Find English-language equivalents



19 BUNDESREPUBLIK
DEUTSCHLAND



DEUTSCHES
PATENT- UND

12 **Offenlegungsschrift**
10 **DE 199 47 832 A 1**

51 Int. Cl.⁷:
C 08 L 71/12
C 08 L 83/04

21 Aktenzeichen: 199 47 832.5
22 Anmeldetag: 5. 10. 1999
43 Offenlegungstag: 13. 4. 2000

9 47 832 A 1

AN 2000-319510 [28] WPINDEX
 TI A fire resistant polyphenylene resin composition useful in the preparation of shaped parts and fire resistant electrical and electronics parts contains an organopolysiloxane having alkyl and aryl residues
 DC A25; A26; V02; V03; V04; W02; W06; X12; X16
 IN MORITOMI S
 PA (SUMO-C) SUMITOMO CHEM CO LTD
 PIA DE 19947832 A1 20000413 (200028)* DE 11[0] <--
 JP 2000178436 A 20000627 (200036) JA 7
US 6258881 B1 20010710 (200141) EN
 ADT DE 19947832 A1 DE 1999-19947832 19991005; JP 2000178436 A JP 1999-204685 19990719; US 6258881 B1 US 1999-413189 19991005
 PRAI JP 1998-285194 19981007

What is DWPI value-add?

- Enhanced patent titles and abstracts
 - Improve search recall and relevance
 - Reduce time required to review results
- Intellectually compiled patent families
 - Precise access to equivalent documents
- **Comprehensive classification and indexing**
 - Improves search recall and relevance

Agenda

- What is the Derwent Word Patents Index (DWPISM) and why should I use it ?
 - the value of value-add
- A tour through a typical database record
 - Invention and member levels
- **Keyword/text searching**
- Assignees & Inventors
- Patent/application numbers
 - Dates & authorities
- Derwent World Patents Index First View

The DWPI default Basic Index (/BI) is formed from value-added text fields

Basic Index
/BI

AN	1999-265576
PI	EP913216 A1 CA2251524 A1 CN1219449 A ...
MEMBER 1	EP913216 A1
MEMBER 2	CA2251524 A1
MEMBER 3	CN1219449 A

invention part
value-added text
Title, Abstract

members part
original text
*Title, Abstract,
Main Claim*

Basic Index
Extension
/BIEX

A DWPI search can be extended to include original text with /BIEX

- On STN it is possible to search DWPI value-added and original patent text separately or simultaneously
- Incorporating the Basic Index Extension (/BIEX) into your DWPI search can improve comprehensiveness

```
=> S OPTICAL(W) (FIBRE# OR FIBER#) AND CABLE#
```

```
L1      17214 S OPTICAL(W) (FIBRE# OR FIBER#) AND CABLE#
```

```
=> SET SFIELDS BI BIEX PERM
```

```
SET COMMAND COMPLETED
```

SET SFIELDS can be used to change the default search index.

```
=> S OPTICAL(W) (FIBRE# OR FIBER#) AND CABLE#
```

```
L2      19402 OPTICAL/BI,BIEX(W) (FIBRE#/BI,BIEX . . .
```

Example: DWPI records concerning PDE4-Inhibitors from Pfizer

=> S PFIZER/PA OR PFIZ/PACO AND ((PHOSPHODIESTERAS? OR PDE) (2A) (4 OR IV) OR PDE4 OR PDEIV) (2A) (INHIBIT? OR BLOCK?)/ACTN

L1 31 L1 AND PHOSPHODIESTERAS? OR P

Use the /ACTN field to search the drug mechanism-of-action.

=> D TI ACTN ACTV USE

L1 ANSWER 1 OF 31 WPINDEX COPYRIGHT 2010 THOMSON REUTERS on STN

TI New crystalline forms of cis-5-fluoro-N-(4-(2-hydroxy-4-methylbenzamido)cyclohexyl)-2-(tetrahydrothiopyran-4-yloxy)-nicotinamide are phosphodiesterase-4 inhibitors useful to treat e.g. inflammatory and respiratory disease

ACTN MECHANISM OF ACTION - **Phosphodiesterase-4 inhibitor.**

ACTV ACTIVITY - Antiinflammatory; Res Gen.; Antiallergic; Antiulcer; C Immunosuppressive; Antiarthritic Litholytic; Antipyretic; Analges

The DWPI enhanced abstract subsection fields are also available individually for customized displays.

USE USE - (I) are useful to treat inflammatory or respiratory disease (adult respiratory distress syndrome, bronchitis, chronic

Classification searching

- DWPI Classification (/DC)
- DWPI Manual Codes (/MC)
- International Patent Classification (/IPC)
- European Patent Classification (/EPC)
- USPTO National Classification (/NCL)
- Japanese Patent Office FI-Terms (/FCL)
- Japanese Patent Office F-Terms (/FTERM)

Why use classification?

=> s (antilock? or anti-lock?) (2W)brak? or abs

L1 27206 (ANTILOCK? OR ANTI-LOCK?) (2W)BRAK? OR ABS

=> s l1 and x22/mc

X22 AUTOMOTIVE ELECTRICS

L2 6212 L10 AND X22/MC

=> s l1 not l2

L3 20994 L10 NOT L11

=> d kwic 1-

L3 ANSWER 1 OF 20994 WPINDEX COPY
TECH. ...polystyrene or acrylonitrile

L3 ANSWER 2 OF 20994 WPINDEX COPYRIGHT 2010 THOMSON REUTERS on STN
USE. ...to-be-detected structure such as absolute (ABS)/increment
(INC) integrated type multi-polar resolver.

L3 ANSWER 3 OF 20994 WPINDEX COPYRIGHT 2010 THOMSON REUTERS on STN
NOV. ...follows the air bearing surface (ABS) of a return yoke (400).

Classification allows you to narrow a search down to a specific field of technology.

The abbreviation 'ABS' has different definitions, a problem that is solved by the use of classifications.

Classification Thesauri

=> e abs/ipc 5

E#	FREQUENCY	AT	TERM
--	-----	--	----
E1	0	1	ABRASIVE(S) * SELECTION OF ABRASIVE(S) PARTICLES FOR B LASTING/IPC
E2	0	1	ABRASIVE(S) * SOAPS AND DETERGENTS CONTAINING ABRASIVE (S)/IPC
E3	0	-->	ABS/IPC
E4	0	1	ABS (ANTILOCK BRAKING SYSTEM)/IPC
E5	0	1	ABSORBENTS/IPC

=> e e4+kt

E1	0	-->	ABS (Antilock Braking System)
E2	362	KT	B60T0008-176/IPC
***** END *****			

=> e e2+ed

E1	362	-->	B60T0008-176/IPC
. . Brake regulation specially adapted to prevent excessive wheel slip during vehicle deceleration, e.g. ABS (B60T0008-1755 takes precedence) ADVANCED VALID FROM 20060101 TO PRESENT (IPC EDITION: 8)			
***** END *****			

Extensive Classification
Thesauri in DWPI allow you to
quickly identify classification
symbols.

Agenda

- What is the Derwent Word Patents Index (DWPISM) and why should I use it ?
 - the value of value-add
- A tour through a typical database record
 - Invention and member levels
- Keyword/text searching
- **Assignees & Inventors**
- Patent/application numbers
 - Dates & authorities
- Derwent World Patents Index First View

Patent Assignees

- Standardization of original data (/PA)
 - 45+ years of Standardization
 - 45+ different sources of Data
- Over 750,000 names in database
 - Matching Names
 - Who owns whom (M&A)

Note: full non-standardized assignee names are searchable for US, EP, DE, WO and JP family members in the /PAO field.

Patent Assignees

=> e apple/pa

E1	2	APPLD PHYSICS PROBL/PA
E2	1	APPLD TECHN ASSOC I/PA
E3	3906 -->	APPLE/PA
E4	1	APPLE ADHESIVES/PA
E5	1	APPLE ARCHERY PROD LLC/PA
E6	1	APPLE BLOSSOM LLC/PA
E7	2	APPLE C L/PA
E8	1	APPLE CAR SALES KK/PA
E9	1	APPLE CO LTD/PA
E10	1	APPLE COMPUTER CO LTD/PA
E11	9	APPLE COMPUTER CORP/PA
E12	1	APPLE COMPUTER FRAN/PA

Browse Patent Assignee name variations using the EXPAND command.

=> e

E13	1	APPLE COMPUTER FRANCE SARL/PA
E14	2302	APPLE COMPUTER INC/PA
E15	1	APPLE COMPUTER INC A CALIFORNIA/PA
E16	4	APPLE COMPUTER LTD/PA
E17	1	APPLE COMPUTER US/PA
E18	11	APPLE COMPUTERS INC/PA
E19	4	APPLE CORP/PA

Patent Assignees

E20	1	APPLE CORP KK/PA
E21	3	APPLE CORP TECHNOLOGIES INC/PA
E22	1	APPLE CORP YG/PA
E23	1	APPLE D L/PA
E24	1	APPLE DOCTOR KK/PA
=> e		
E25	2	APPLE DYNAMICS INTELLECTUAL PROPERTY LTD/PA
E26	1	APPLE E G/PA
E27	4	APPLE ENG LTD/PA
E28	1	APPLE ESSENCE CO LTD/PA
E29	1	APPLE G D/PA
E30	1	APPLE G L/PA
E31	1	APPLE H C/PA
E32	1	APPLE H P/PA
E33	1	APPLE HOUSE ELECTRONICS LTD/PA
E34	1753	APPLE INC/PA
E35	5	APPLE IRYO KIKI KK/PA
E36	2	APPLE J/PA

Patent Assignees

=> s e9-e22,e34

L1 3749 ("APPLE CO LTD"/PA OR "APPLE COMPUTER CO LTD"/PA OR "APPLE COMPU
 TER CORP"/PA OR "APPLE COMPUTER FRAN"/PA OR "APPLE COMPUTER FRAN
 CE SARL"/PA OR "APPLE COMPUTER INC"/PA OR "APPLE
 CALIFORNIA"/PA OR "APPLE COMPUTER LTD"/PA OR "APP
 US"/PA OR "APPLE COMPUTERS INC"/PA OR "APPLE CORP
 CORP KK"/PA OR "APPLE CORP TECHNOLOGIES INC"/PA O
 YG"/PA OR "APPLE INC"/PA)

Search items of
 interest from the
 EXPAND list.

=> d

L1 ANSWER 1 OF 3749 WPINDEX COPYRIGHT 2010 THOMSON REUTERS on STN
 AN 2010-B18363 [10] WPINDEX
 TI Apparatus for providing LED backlight to LCD display screen, has several
 LED strings connected to phase locked loop circuit and pulse width
 modulation drive signals generating circuit
 DC P81; P85; U14; U22; U23; X26
 IN SMITH E
 PA (APPY-C) **APPLE INC**
 CYC 1
 PI US 20100020004 A1 20100128 (201010)* EN 18[10]
 ADT US 20100020004 A1 US 2008-178471 20080723
 PRAI US 2008-178471 20080723
 IPCI G02F0001-13 [I,C]; G02F0001-13357 [I,A]; G09G0003-36 [I,A]; G09G0003-36 [I,C]

Patent Assignee Codes

- 21,000 standardized assignee codes
 - Codes for Japanese assignee names
- Patent Assignee Codes printed manual
 - Web Version (link below)
- STN online thesaurus

Patent Assignee Codes Lookup Facility:

<http://scientific.thomsonreuters.com/support/patents/dwpieref/reftools/companycodes/lookup/>

Patent Assignee Codes

=> e apple/paco

E#	FREQUENCY	AT	TERM
--	-----	--	----
E1	0	1	APPLAUSE SYSTEM KK/PACO
E2	0	1	APPLD/PACO
E3	0	17 -->	APPLE/PACO
E4	0	1	APPLE & FRIENDS DESIGN PTE LTD/PACO
E5	0	1	APPLE BLOSSOM LLC/PACO
E6	0	1	APPLE CAR SALES KK/PACO
E7	0	1	APPLE CO LTD/PACO
E8	0	1	APPLE COMPUTER CO LTD/PACO
E9	0	1	APPLE COMPUTER CORP/PACO
E10	0	1	APPLE COMPUTER FRANCE SARL/PACO
E11	0	1	APPLE COMPUTER INC/PACO
E12	0	1	APPLE COMPUTER INC A CALIFORNIA/PACO

EXPAND a
company name in
the field /PACO.

=> e e8+all

E1	0	-->	APPLE COMPUTER CO LTD/PACO
E2	3740	CODE	APPY-C/PACO
***** END *****			

Open the thesaurus
using the relationship
code +ALL.

Patent Assignee Codes

=> e e2+def

```

E1          3740    -->  APPY-C/PACO
E2          DEF    APPLE COMPUTER CO LTD/PACO
E3          DEF    APPLE COMPUTER CORP/PACO
E4          DEF    APPLE COMPUTER FRANCE SARL/PACO
E5          DEF    APPLE COMPUTER INC/PACO
E6          DEF    APPLE COMPUTER LTD/PACO
E7          DEF    APPLE COMPUTERS INC/PACO
E8          DEF    APPLE INC/PACO
*****      END      *****
  
```

These naming variations are covered by the Company Code APPY-C.

=> s e2

L2 3740 APPY-C/PACO

Searching by name
retrieved more documents.

=> d ti pn

```

L2  ANSWER 1 OF 3740  WPINDEX COPYRIGHT 2010          THOMSON REUTERS on STN
TI  Apparatus for providing LED backlight to LCD display screen, has
    several LED strings connected to phase locked loop circuit and pulse
    width modulation drive signals generating circuit
PI  US 20100020004  A1 20100128 (201010)* EN 18[10]
  
```

Patent Assignee Codes

=> s l1 not l2

L3 10 L1 NOT L2

=> d ti pa pn

L3 ANSWER 1 OF 10 WPINDEX COPYRIGHT 2010 THOMSON REUTERS on STN
 TI Connector for mannequin
 PA (APPL-N) **APPLE CORP**
 PI TW 323855 U 20071221 (200966)* ZH 0[1]

That's a different Apple Corporation.

=> s l2 not l1

L4 1 L2 NOT L1

=> d ti pa pn

L7 ANSWER 1 OF 1 WPINDEX COPYRIGHT 2010
 TI Operand permutation with replication pe
 register file for multimedia and scient
 PA (**APPY-C**) APPLE; (IBMC-C) IBM CORP; (MOTI-C) MOTOROLA INC
 PI US 5996057 A 19991130 (200006)* EN 11[8]

We also missed one document in the /PA search.

Searching with Patent Assignee Codes is both more precise and more comprehensive.

Patent Assignee Codes

- Standard vs. Non-Standard
 - STANDARD AAAA-C
 - NON-STANDARD AAAA-N
 - SOVIET INSTITUTES AAAA-R
 - INDIVIDUALS AAAA-I

Do not use *non-standard codes* for searching!

Searching for Inventors

- Inventors /IN (or /AU)
- Inventors from the DWPI basic document
- Available from 1978
- Surname Initials format, e.g. SMITH J/IN
- Inventors (/IN) for Japanese documents are only included from 6/2005 onwards

Note: full non-standardized inventor names are searchable for US, EP, DE, WO and JP family members in the /INO field.

Agenda

- What is the Derwent Word Patents Index (DWPISM) and why should I use it ?
 - the value of value-add
- A tour through a typical database record
 - Invention and member levels
- Keyword/text searching
- Assignees & Inventors
- Patent/application numbers
 - Dates & authorities
- Derwent World Patents Index First View

Numbers and Dates

- Publication Numbers and dates (PN, PD)
 - EP1116932/PN, 20010718/PD
- Application Numbers and dates (AP, AD)
 - EP2000-126646/AP, 20001205/AD
- Priority Numbers and dates (PRN, PRD)
 - US2000-176284/PRN, 20000114/PRD

Publication numbers

- STN has automatic search edits to handle many common formats, e.g. with commas or slashes
- Take out any periods and the publication kind code; include the 2-digit country code prefix
- Continuous series
 - Search U.S. Patent 4,718,426 **A** as US 4,718,426/PN
- Annual series
 - Search WO 99/12345 **A1** as WO 99/12345/PN
 - Search WO 03/04255 **A2** as WO 03/04255/PN

Application/Priority numbers

- Take out all commas, slashes, periods, suffixes and prefixes (including series); use the 2-digit country code prefix and application year
- United States application 9/101,138 2000
=> S US2000-101138/AP
- US provisional (series 60) application numbers have a P appended, e.g. US2003-440129**P**/PRN
- Coverage of application numbers (AP) is complete from DW 199216 onwards

Examples: making the most of DWPI search & display options

Example 1: comprehensive company search
Additional records for Syngenta using Agent data

Example 2: search with the full original inventor name
Records for the Inventor Ralf Michael Schmidt

1. Retrieve additional DWPI records for Syngenta using Agent data

```
=> s syngenta/ag not (syngenta/pa or sygn-c/paco)
```

```
L1 29 SYNGENTA/AG NOT (SYNGENTA/PA OR SY
```

```
=> d ti in pa pn hit
```

```
L1 ANSWER 1 OF 29 WPINDEX COPYRIGHT 2010
```

Using the search field
/AG 29 additional
documents can be found.

```
TI New nucleic acid encoding plastid transit peptide from Glauco-  
cystophyte, useful for stably expressing a heterologous polypeptide in  
a plant and for producing transgenic plants with desired traits
```

```
IN HIPSKIND J; MILES S; WARREN G W
```

```
PA (HIPS-I) HIPSKIND J; (MILE-I) MILES S; (WARR-I) WARREN G W
```

```
PI US 20090205075 A1 20090813 (200955)* EN 19[0]
```

```
Member(0001)
```

```
AG SYNGENTA BIOTECHNOLOGY, INC.;PATENT DEPARTMENT
```

```
AGA: 3054 CORNWALLIS ROAD, PO BOX 10055, RESEARCH TRIANGLE PARK, NC, US
```

This record would not have
been retrieved without
using the **AG** field.

2. Search with full inventor name for the inventor Ralf Michael Schmidt

```
=> s schmidt r/in
L2      1864 SCHMIDT R/IN
```

Traditional Search.

```
=> d ti hit ino
```

```
L2      ANSWER 1 OF 1864  WPINDEX COPYRIGHT 2010          THOMSON REUTERS on STN
TI      Wheat flour for producing foodstuffs with decreased glycemic index
        comprises starch component comprising amylase and resistant starch
IN      FROHBERG C; SCHMIDT R
```

```
Member (0001)
```

```
INO     FROHBERG, Claus; SCHMIDT, Ralf-Christian
```

The wrong Mr. Schmidt

2. Search with full inventor name for the inventor Ralf Michael Schmidt

=> S (RALF (P) MICHAEL (P) SCHMIDT) /INO

L5 24 (RALF (P) MICHAEL (P) SCHMIDT) /INO

Member Level Search.

=> d ti in pa pn hit

L5 ANSWER 1 OF 24 WPINDEX COPYRIGHT 2010 THOMSON REUTERS on STN
 TI Method for increased production of transgenic plants with resistance
 to pathogens, especially mildew in barley, in which a DNA sequence is
 introduced and expressed with a coding for a peroxidase activity
 IN FRANK M; SCHMIDT R; STAUDER S; SCHMIDT R M
 PA (BADI-C) BASF PLANT SCI GMBH
 PI WO 2006000319 A2 20060105 (200608)* DE 96[1]
 DE 102004030608 A1 20060126 (200609) DE
 EP 1759005 A2 20070307 (200720) DE
 AU 2005256390 A1 20060105 (200731) EN
 CN 1973045 A 20070530 (200763) ZH
 IN 2007CN00310 P4 20070824 (200780) EN
 JP 2008503227 W 20080207 (200812) JA 68
 BR 2005012568 A 20080325 (200824) PT
 US 20080282425 A1 20081113 (200877) EN

Member (0001)

INO FRANK, Markus; SCHMIDT, Ralf-Michael; STAUDER, Sandra

Agenda

- What is the Derwent Word Patents Index (DWPISM) and why should I use it ?
 - the value of value-add
- A tour through a typical database record
 - Invention and member levels
- Keyword/text searching
- Assignees & Inventors
- Patent/application numbers
 - Dates & authorities
- **Derwent World Patents Index First View**

DWPI First View (WPIFV)

- Patent-based rolling bibliographic file of newly published patents not yet in DWPI
- Patents are added 1-10 days after publication for all major issuing authorities covered in DWPI
- Original title, abstract, images, main claim, US classification and Patent Assignee Codes
- Machine assisted translations for JP patents
- **DWPI + WPIFV = complete coverage**

WPIFV is a rolling file of newly published patents not yet in DWPI

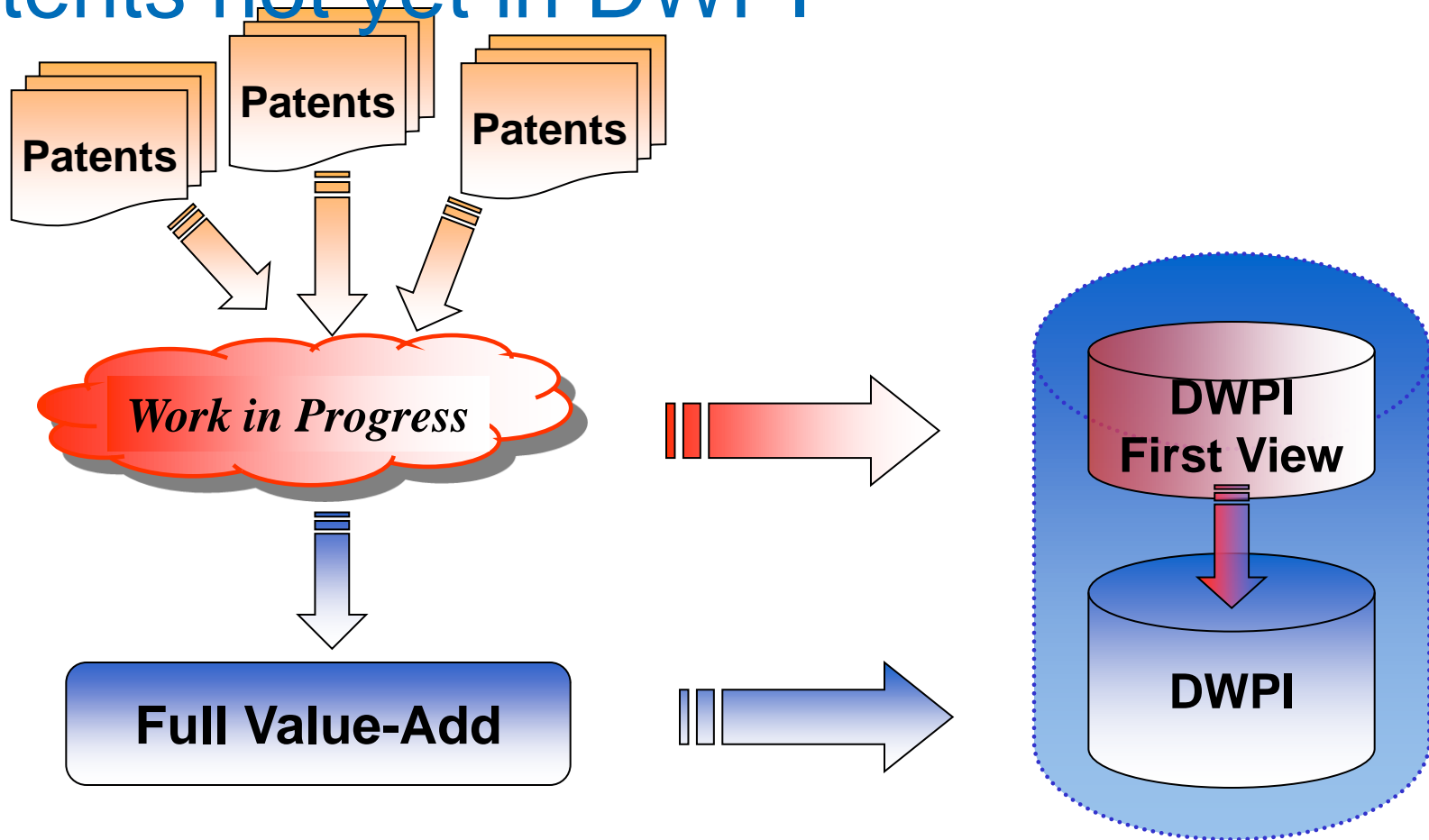

Summary

- What is the Derwent Word Patents Index (DWPISM) and why should I use it ?
 - the value of value-add
- A tour through a typical database record
 - Invention and member levels
- Keyword/text searching
- Assignees & Inventors
- Patent/application numbers
 - Dates & authorities
- Derwent World Patents Index First View

Introduction to Derwent World Patents Index[®] (DWPI)

STN[®]

www.stn-international.com